



# A-Series, AXC - Style-2 & 3, Rod Scraper with Backup Wiper

Medium Duty

**MFPSEALS**  
www.mfpseals.com

AXC

## HYDROWYPE

### A-SERIES, AXC - STYLE-2 & 3 ROD SCRAPER WITH BACKUP WIPER

The Gadjets Hydrowype A-Series, AXC - Style 2 & 3 Rod Scrapers are designed for Medium to Heavy-Duty applications and incorporate a backup wiper to collect any fine contaminant that may get past the Scraper, further ensuring that debris doesn't get into the Hydraulic system.

*The standard compound for the X-PAC® seal is U2151. Other compounds are available. Consult MFP Seals Engineering for more information.*

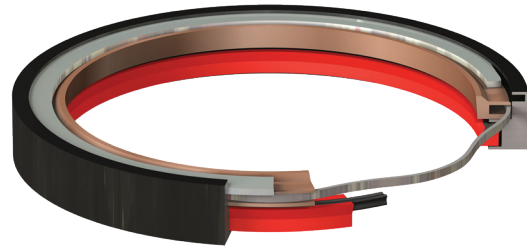

An A-Series, Style-2 Metallic Scraper. A serpentine spring is used on sizes ≥1.5" I.D.



An A-Series, Style-3 Metallic Scraper. Dual C-springs are used on sizes <1.5" I.D.

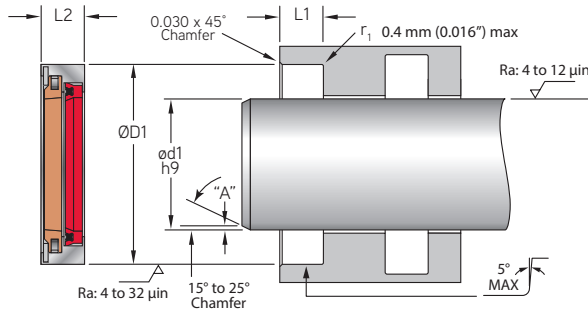

### HYDROWYPE PART NUMBER

**AXC-1000X1500-312C/U2151**  
SEAL TYPE    ød1    ØD1    L1    X-PAC® MATERIAL  
CARBON STEEL CAN

\*Unfinished parts are susceptible to oxidation and should not be stored for long periods without appropriate treatment. Parts will be shipped in plastic bags with a light coating of machine oil to prevent corrosion.

ROD SCRAPERS

	PRESS-IN ROD APPLICATION		
	ød1	ØD1	L1
<b>.312" - GROOVE</b>	h9	+.001/-0.001	+.015/-0.000
AXC-1000X1500-312C/U2151	1.000	1.500	0.312
AXC-1125X1625-312C/U2151	1.125	1.625	0.312
AXC-1250X1750-312C/U2151	1.250	1.750	0.312
AXC-1375X1875-312C/U2151	1.375	1.875	0.312
AXC-1500X2000-312C/U2151	1.500	2.000	0.312
AXC-1750X2250-312C/U2151	1.750	2.250	0.312
AXC-2000X2500-312C/U2151	2.000	2.500	0.312
AXC-2125X2625-312C/U2151	2.125	2.625	0.312
AXC-2500X3000-312C/U2151	2.500	3.000	0.312
AXC-3000X3500-312C/U2151	3.000	3.500	0.312
AXC-3500X4000-312C/U2151	3.500	4.000	0.312