



A-Series, AO Rod Scraper

Medium Duty

HYDROWYPE

A-SERIES, AO ROD SCRAPERS

AO scrapers are an extension of the Style-2 scraper design, incorporating an o-ring to seal the clearance between the scraper and housing, thus preventing ingress around the outside of the scraper. The scraper body accommodates both a serpentine spring and an o-ring, positioned in a "double-stacked" groove, with the o-ring positioned on the outer diameter of the body and extending approximately 0.02" in diameter beyond the outer diameter of the body. This permits compression of the o-ring against the housing groove (counterbore), thus sealing the path of ingress outside of the scraper body.

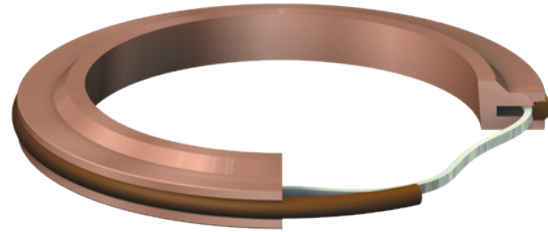

HYDROWYPE PART NUMBER

AO-01B/V7155

SEAL TYPE DASH# FINISH O-RING COMPOUND**

FINISH DESIGNATION

B = UNFINISHED* (Standard) N = NICKEL
C = CADMIUM Z = ZINC

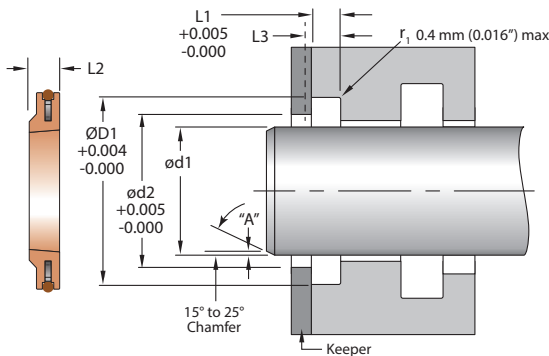

Scrapers are typically held in place by a Keeper/Follower plate or Retaining Ring.

*Unfinished parts are susceptible to oxidation and should not be stored for long periods without appropriate treatment. Parts will be shipped in plastic bags with light coating of machine oil to prevent corrosion.

**For a list of available elastomeric compounds for o-rings, please refer to page 45 & 46.

ROD SCRAPERS

PART NUMBER	ROD APPLICATION				
	ød1	ØD1	ød2	L1	L3
.104" - GROOVE	NOMINAL	+0.004/-0.000	+0.005/-0.000	+0.005/-0.000	+0.005/-0.000
AO-16	1.438	1.739	1.605	0.104	0.135
AO-17	1.500	1.802	1.668	0.104	0.135
AO-18	1.625	1.927	1.793	0.104	0.135
AO-19	1.750	2.052	1.918	0.104	0.135
AO-20	1.875	2.177	2.043	0.104	0.135
AO-21	2.000	2.302	2.178	0.104	0.135
AO-22	2.125	2.427	2.303	0.104	0.135
AO-23	2.250	2.552	2.428	0.104	0.135
AO-24	2.375	2.677	2.553	0.104	0.135
AO-25	2.500	2.802	2.678	0.104	0.135
.119" - GROOVE	NOMINAL	+0.004/-0.000	+0.005/-0.000	+0.005/-0.000	+0.005/-0.000
AO-26	2.625	2.989	2.834	0.119	0.150
AO-27	2.750	3.114	2.959	0.119	0.150
AO-28	2.875	3.239	3.084	0.119	0.150
AO-29	3.000	3.364	3.209	0.119	0.150
AO-30	3.125	3.489	3.334	0.119	0.150
AO-31	3.250	3.614	3.459	0.119	0.150
AO-32	3.375	3.739	3.584	0.119	0.150
AO-33	3.500	3.864	3.709	0.119	0.150

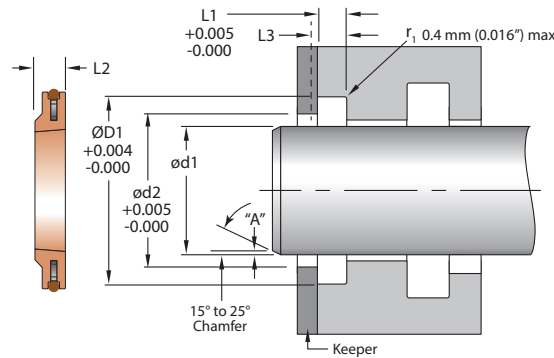

AO

PART NUMBER	ROD APPLICATION				
	ød1	ØD1	ød2	L1	L3
.119" - GROOVE	NOMINAL	+0.004/-0.000	+0.005/-0.000	+0.005/-0.000	+0.005/-0.000
AO-34	3.625	3.989	3.834	0.119	0.150
AO-35	3.750	4.114	3.959	0.119	0.150
AO-36	3.875	4.239	4.084	0.119	0.150
.135" - GROOVE	NOMINAL	+0.004/-0.000	+0.005/-0.000	+0.005/-0.000	+0.005/-0.000
AO-37	4.000	4.427	4.240	0.135	0.166
AO-38	4.125	4.552	4.365	0.135	0.166
AO-39	4.250	4.677	4.490	0.135	0.166
AO-40	4.375	4.802	4.615	0.135	0.166
AO-41	4.500	4.927	4.740	0.135	0.166
AO-42	4.625	5.052	4.865	0.135	0.166
AO-43	4.750	5.177	4.990	0.135	0.166
AO-44	4.875	5.302	5.115	0.135	0.166
AO-45	5.000	5.427	5.240	0.135	0.166
AO-46	5.125	5.552	5.365	0.135	0.166
AO-47	5.250	5.677	5.490	0.135	0.166
AO-48	5.375	5.802	5.615	0.135	0.166
AO-49	5.500	5.927	5.740	0.135	0.166
.151" - GROOVE	NOMINAL	+0.004/-0.000	+0.005/-0.000	+0.005/-0.000	+0.005/-0.000
AO-50	5.625	6.114	5.896	0.151	0.182
AO-51	5.750	6.239	6.022	0.151	0.182
AO-52	5.875	6.364	6.146	0.151	0.182
AO-53	6.000	6.489	6.272	0.151	0.182
AO-54	6.250	6.739	6.522	0.151	0.182
AO-55	6.500	6.989	6.772	0.151	0.182
AO-56	6.750	7.239	7.022	0.151	0.182
AO-57	7.000	7.489	7.272	0.151	0.182
AO-58	7.250	7.739	7.522	0.151	0.182
AO-59	7.500	7.989	7.772	0.151	0.182
AO-60	7.750	8.239	8.022	0.151	0.182
AO-61	8.000	8.489	8.272	0.151	0.182
AO-62	8.500	8.989	8.772	0.151	0.182
AO-63	9.000	9.489	9.272	0.151	0.182
AO-64	9.500	9.989	9.772	0.151	0.182
AO-65	10.000	10.489	10.272	0.151	0.182

ROD SCRAPERS



A-Series, AO Rod Scraper

Medium Duty

AO

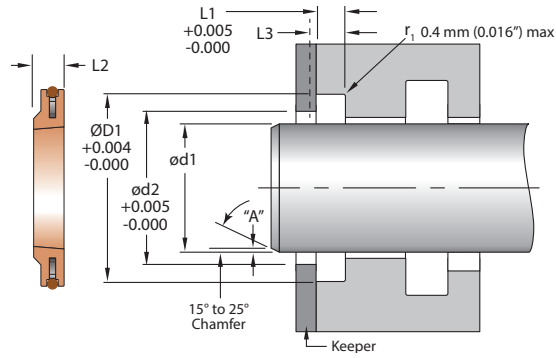

PART NUMBER	ROD APPLICATION				
	ød1	ØD1	ød2	L1	L3
.151" - GROOVE	NOMINAL	+0.004/-0.000	+0.005/-0.000	+0.005/-0.000	+0.005/-0.000
AO-66	10.500	10.989	10.772	0.151	0.182
AO-67	11.000	11.489	11.272	0.151	0.182
.166" - GROOVE	NOMINAL	+0.004/-0.000	+0.005/-0.000	+0.005/-0.000	+0.005/-0.000
AO-68	11.500	11.989	11.772	0.166	0.197
AO-69	12.000	12.489	12.272	0.166	0.197
AO-70	12.500	12.989	12.772	0.166	0.197
AO-71	13.000	13.489	13.272	0.166	0.197

ROD SCRAPERS