



BRS - Rod Buffer Seal

A product of MFP Seals.

BRS

BRS - ROD BUFFER SEAL

MFP Seals' BRS is designed for use as a buffer seal or as the primary sealing element. When used as a buffer seal a primary rod seal would be designed into the groove downstream of the pressure. The BRS seal is composed of a two piece design consisting of a filled PTFE ring along with a rubber energizer. The BRS offers low friction and long life due to its material composition.



This seal is available in T1125 and T5100, with an N6001, V7100 or V7155 O-Ring Expander.

For increased chemical and temperature resistance, other compounds are available (See pages 20-37).

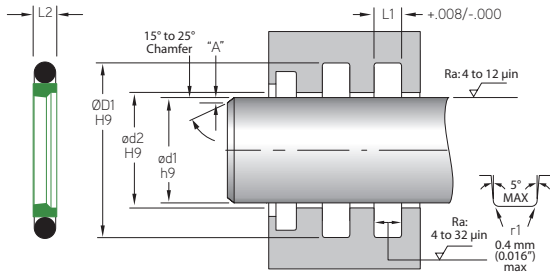

MFP PART NUMBER

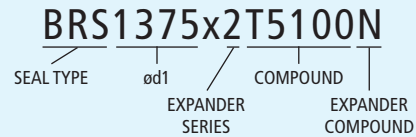

Pressure: 350 bar (5,000 psi)

Max. Velocity: 4.0 m/s (13 ft./s)

BUFFER RINGS

MFP PART NUMBER	ROD APPLICATION					O-Ring DASH NO.
	ød1	ØD1	L1	ød2		
TOLERANCE	h9	H9	+0.008/-0.000	H9		
BRS0437X1	0.438	0.724	0.126	0.439		-113
BRS0500X1	0.500	0.786	0.126	0.501		-114
BRS0562X1	0.563	0.849	0.126	0.564		-115
BRS0625X1	0.625	0.911	0.126	0.626		-116
BRS0687X1	0.687	0.974	0.126	0.689		-117
BRS0750X1	0.750	1.036	0.126	0.751		-118
BRS0875X1	0.875	1.161	0.126	0.876		-120
BRS1000X1	1.000	1.286	0.126	1.001		-122
BRS1125X1	1.125	1.411	0.126	1.126		-124
BRS1250X1	1.250	1.536	0.126	1.251		-126
BRS1375X1	1.375	1.661	0.126	1.376		-128
BRS1500X1	1.500	1.786	0.126	1.501		-130
BRS1750X1	1.750	2.036	0.126	1.751		-134
BRS0750X2	0.750	1.170	0.165	0.751		-213
BRS0812X2	0.813	1.233	0.165	0.814		-214
BRS0875X2	0.875	1.295	0.165	0.876		-215
BRS0937X2	0.938	1.358	0.165	0.939		-216
BRS1000X2	1.000	1.420	0.165	1.001		-217
BRS1062X2	1.063	1.483	0.165	1.064		-218
BRS1125X2	1.125	1.545	0.165	1.126		-219
BRS1187X2	1.188	1.608	0.165	1.189		-220
BRS1250X2	1.250	1.670	0.165	1.251		-221
BRS1312X2	1.313	1.733	0.165	1.314		-222
BRS1375X2	1.375	1.795	0.165	1.376		-222

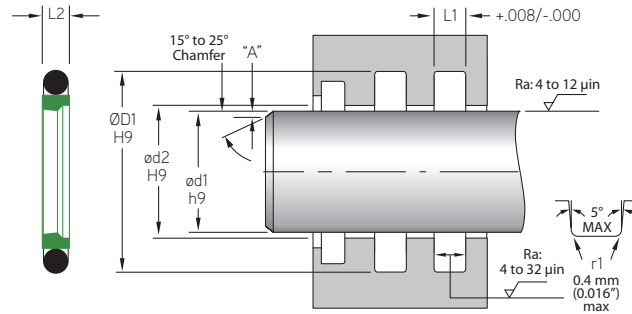

BRS

MFP PART NUMBER	ROD APPLICATION				O-Ring DASH NO.
	ød1	ØD1	L1	ød2	
TOLERANCE	h9	H9	+.008/-0.000	H9	
BRS1437X2	1.438	1.859	0.165	1.439	-223
BRS1500X2	1.500	1.921	0.165	1.501	-223
BRS1750X2	1.750	2.171	0.165	1.751	-225
BRS1875X2	1.875	2.296	0.165	1.871	-226
BRS2000X2	2.000	2.421	0.165	2.001	-227
BRS2250X2	2.250	2.671	0.165	2.251	-229
BRS2500X2	2.500	2.921	0.165	2.501	-231
BRS2750X2	2.750	3.171	0.165	2.751	-233
BRS3000X2	3.000	3.421	0.165	3.001	-235
BRS3500X2	3.500	3.921	0.165	3.501	-239
BRS4000X2	4.000	4.421	0.165	4.001	-243
BRS4500X2	4.500	4.921	0.165	4.501	-247
BRS1500X3	1.500	2.094	0.248	1.501	-327
BRS1562X3	1.563	2.157	0.248	1.564	-327
BRS1625X3	1.625	2.219	0.248	1.626	-328
BRS1687X3	1.688	2.282	0.248	1.689	-328
BRS1750X3	1.750	2.344	0.248	1.751	-329
BRS1812X3	1.813	2.407	0.248	1.814	-329
BRS1875X3	1.875	2.469	0.248	1.876	-330
BRS1937X3	1.938	2.532	0.248	1.939	-330
BRS2000X3	2.000	2.594	0.248	2.001	-331
BRS2125X3	2.125	2.719	0.248	2.126	-332
BRS2250X3	2.250	2.844	0.248	2.251	-333
BRS2375X3	2.375	2.969	0.248	2.376	-334
BRS2500X3	2.500	3.094	0.248	2.501	-335
BRS2625X3	2.625	3.219	0.248	2.626	-336
BRS2750X3	2.750	3.344	0.248	2.751	-337
BRS2875X3	2.875	3.469	0.248	2.876	-338
BRS3000X3	3.000	3.594	0.248	3.001	-339
BRS3125X3	3.125	3.719	0.248	3.126	-340
BRS3250X3	3.250	3.844	0.248	3.251	-341
BRS3375X3	3.375	3.969	0.248	3.376	-342
BRS3500X3	3.500	4.094	0.248	3.501	-343
BRS3625X3	3.625	4.219	0.248	3.626	-344
BRS3750X3	3.750	4.344	0.248	3.751	-345
BRS3875X3	3.875	4.469	0.248	3.876	-346

BUFFER RINGS



BRS - Rod Buffer Seal

A product of MFP Seals.

MFPSEALS
www.mfpseals.com

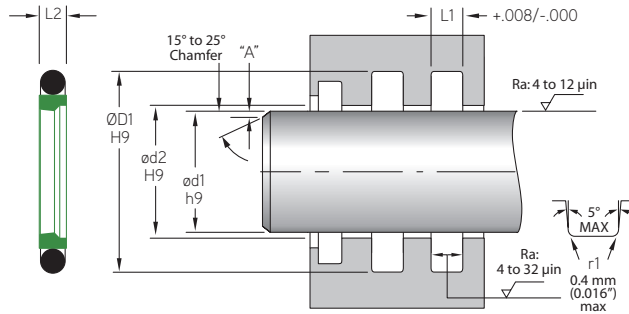

BRS

BUFFER RINGS

MFP PART NUMBER	ROD APPLICATION				O-Ring DASH NO.
	ød1	ØD1	L1	ød2	
TOLERANCE	h9	H9	+0.008/-0.000	H9	
BRS4000X3	4.000	4.594	0.248	4.001	-347
BRS4125X3	4.125	4.719	0.248	4.126	-348
BRS4250X3	4.250	4.844	0.248	4.251	-349
BRS4375X3	4.375	4.969	0.248	4.376	-350
BRS4500X3	4.500	5.094	0.248	4.501	-351
BRS4625X3	4.625	5.219	0.248	4.626	-352
BRS4750X3	4.750	5.344	0.248	4.752	-353
BRS4875X3	4.875	5.469	0.248	4.877	-354
BRS5000X3	5.000	5.594	0.248	5.002	-355
BRS5125X3	5.125	5.719	0.248	5.127	-356
BRS5250X3	5.250	5.844	0.248	5.252	-357
BRS5375X3	5.375	5.969	0.248	5.377	-358
BRS5500X3	5.500	6.094	0.248	5.502	-359
BRS5625X3	5.625	6.219	0.248	5.627	-360
BRS5750X3	5.750	6.344	0.248	5.752	-361
BRS6000X3	6.000	6.594	0.248	6.002	-362
BRS6250X3	6.250	6.844	0.248	6.252	-363
BRS6500X3	6.500	7.094	0.248	6.502	-364
BRS6750X3	6.750	7.344	0.248	6.752	-365
BRS7000X3	7.000	7.594	0.248	7.002	-366
BRS7250X3	7.250	7.844	0.248	7.252	-367
BRS7500X3	7.500	8.094	0.248	7.502	-368
BRS7750X3	7.750	8.344	0.248	7.752	-369
BRS8000X3	8.000	8.594	0.248	8.002	-370
BRS4000X4	4.000	4.807	0.319	4.001	-424
BRS4250X4	4.250	5.057	0.319	4.251	-426
BRS4500X4	4.500	5.307	0.319	4.501	-428
BRS4750X4	4.750	5.557	0.319	4.752	-430
BRS5000X4	5.000	5.807	0.319	5.002	-432
BRS5250X4	5.250	6.057	0.319	5.252	434
BRS5500X4	5.500	6.307	0.319	5.502	-436
BRS5750X4	5.750	6.557	0.319	5.752	-437
BRS6000X4	6.000	6.807	0.319	6.002	-438
BRS6250X4	6.250	7.057	0.319	6.252	-439
BRS6500X4	6.500	7.307	0.319	6.502	-440
BRS6750X4	6.750	7.557	0.319	6.752	-441

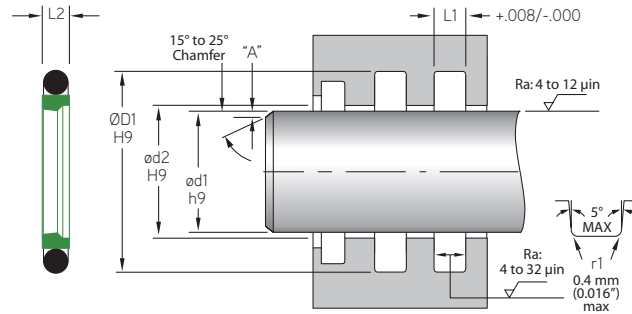

BRS

MFP PART NUMBER	ROD APPLICATION				O-Ring DASH NO.
	ød1	ØD1	L1	ød2	
TOLERANCE	h9	H9	+.008/-0.000	H9	
BRS7000X4	7.000	7.806	0.319	7.002	-442
BRS7250X4	7.250	8.056	0.319	7.252	-443
BRS7500X4	7.500	8.306	0.319	7.502	-444
BRS7750X4	7.750	8.556	0.319	7.752	-445
BRS8000X4	8.000	8.806	0.319	8.003	-445
BRS8250X4	8.250	9.056	0.319	8.253	-446
BRS8500X4	8.500	9.306	0.319	8.503	-446
BRS8750X4	8.750	9.556	0.319	8.753	-447
BRS9000X4	9.000	9.806	0.319	9.003	-447
BRS9250X4	9.250	10.056	0.319	9.253	-448
BRS9500X4	9.500	10.306	0.319	9.503	-448
BRS9750X4	9.750	10.556	0.319	9.753	-449
BRS10000X4	10.000	10.944	0.319	10.003	-450
BRS10500X4	10.500	11.444	0.319	10.503	-451
BRS11000X4	11.000	11.944	0.319	11.003	-452
BRS11500X4	11.500	12.444	0.319	11.503	-453
BRS12000X4	12.000	12.944	0.319	12.003	-454
BRS12500X4	12.500	13.444	0.319	12.503	-454
BRS13000X4	13.000	13.944	0.319	13.003	-455
BRS13500X4	13.500	14.444	0.319	13.503	-456
BRS14000X4	14.000	14.944	0.319	14.003	-457
BRS14500X4	14.500	15.444	0.319	14.503	-458
BRS15000X4	15.000	15.944	0.319	15.003	-459
BRS15500X4	15.500	16.444	0.319	15.503	-460
BRS16000X4	16.000	16.944	0.319	16.003	-461
BRS16500X4	16.500	17.444	0.319	16.503	-462
BRS17000X4	17.000	17.944	0.319	17.003	-463
BRS17500X4	17.500	18.444	0.319	17.503	-464
BRS18000X4	18.000	18.944	0.319	18.003	-465
BRS18500X4	18.500	19.444	0.319	18.503	-466
BRS19000X4	19.000	19.944	0.319	19.003	-467
BRS19500X4	19.500	20.444	0.319	19.503	-468
BRS20000X4	20.000	20.944	0.319	20.003	-469

BUFFER RINGS