



TPS - SQUARE (2 PC.) PISTON SEAL

MFP Seals' TPS Piston seal utilize a square profile to minimize gland space requirements on the piston. For use in bidirectional sealing the proprietary T1075 PTFE sealing element offers a low coefficient of friction while the O-Ring expander creates an effective compression seal. Typical applications are light to medium duty hydraulic cylinders & actuators.



This seal is available in Filled PTFE: T1075, T1125, and T5100, with an N6001, V7100 or V7155 O-Ring Expander.

For increased chemical and temperature resistance, other compounds are available (See pages 20-37).

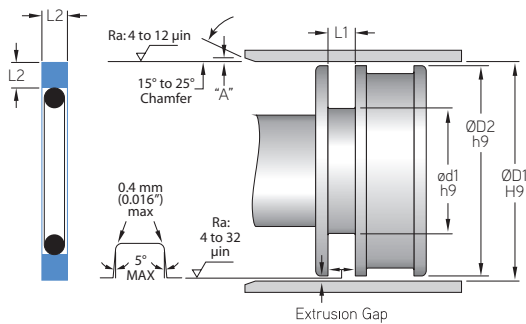

MFP PART NUMBER
MFP-TPS-050T1075N

SEAL TYPE: TPS
COMPOUND: 050
EXPANDER COMPOUND: T1075N

Pressure: 250 bar (3625 psi)

Max. Velocity: 4.0 m/s (13 ft./s)

MFP PART NUMBER	PISTON APPLICATION					O-Ring DASH NO.
	ØD1	ød1	ØD2	L1	L2	
TOLERANCE	H9	h9	h9	+0.01/-0.01	+0.02/-0.02	
MFP-TPS-050	0.500	0.240	0.499	0.083	0.070	-009
MFP-TPS-062	0.625	0.365	0.624	0.083	0.070	-011
MFP-TPS-075	0.750	0.490	0.749	0.083	0.070	-013
MFP-TPS-087	0.875	0.615	0.874	0.083	0.070	-016
MFP-TPS-100	1.000	0.740	0.999	0.083	0.070	-017
MFP-TPS-112	1.125	0.865	1.124	0.083	0.070	-019
MFP-TPS-125	1.250	0.990	1.249	0.083	0.070	-022
MFP-TPS-137	1.375	1.115	1.374	0.083	0.070	-022
MFP-TPS-150	1.500	1.240	1.499	0.083	0.070	-025
TOLERANCE	H9	h9	h9	+0.02/-0.02	+0.02/-0.02	
MFP-TPS-156	1.562	1.172	1.561	0.122	0.109	-123
MFP-TPS-162	1.625	1.233	1.624	0.122	0.109	-123
MFP-TPS-168	1.687	1.295	1.686	0.122	0.109	-124
MFP-TPS-175	1.750	1.358	1.749	0.122	0.109	-125
MFP-TPS-187	1.875	1.483	1.874	0.122	0.109	-127
MFP-TPS-200	2.000	1.608	1.999	0.130	0.115	-129
MFP-TPS-212	2.125	1.733	2.124	0.130	0.115	-131
MFP-TPS-225	2.250	1.858	2.249	0.130	0.115	-133
MFP-TPS-237	2.375	1.983	2.374	0.130	0.115	-135



TPS - Square (2 PC.) Piston Seal

A product of MFP Seals.

MFPSEALS
www.mfpseals.com

TPS - T1075N

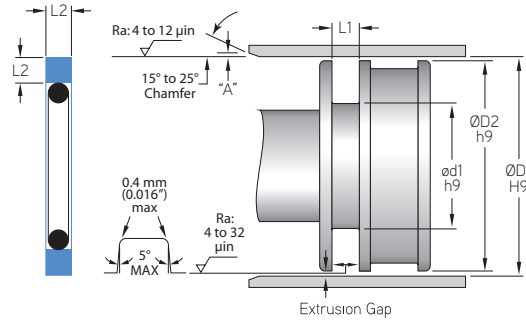

PISTON ASSEMBLIES

MFP PART NUMBER	PISTON APPLICATION					O-Ring DASH NO.
	ØD1	ød1	ØD2	L1	L2	
TOLERANCE	H9	h9	h9	+0.002/-0.002	+0.002/-0.002	
MFP-TPS-250	2.500	2.108	2.499	0.130	0.115	-137
MFP-TPS-262	2.625	2.233	2.624	0.130	0.115	-139
MFP-TPS-275	2.750	2.358	2.749	0.130	0.115	-141
MFP-TPS-287	2.875	2.483	2.874	0.130	0.115	-143
MFP-TPS-300	3.000	2.608	2.999	0.130	0.115	-145
MFP-TPS-325	3.250	2.858	3.249	0.130	0.115	-149
MFP-TPS-337	3.375	2.983	3.374	0.130	0.115	-150
MFP-TPS-350	3.500	3.108	3.499	0.130	0.115	-151
MFP-TPS-362	3.625	3.233	3.624	0.130	0.115	-152
MFP-TPS-375	3.750	3.358	3.749	0.130	0.115	-152
MFP-TPS-400	4.000	3.608	3.999	0.130	0.115	-153
MFP-TPS-425	4.250	3.858	4.249	0.130	0.115	-154
MFP-TPS-450	4.500	4.108	4.499	0.130	0.115	-155
MFP-TPS-475	4.750	4.358	4.749	0.130	0.115	-156
MFP-TPS-487	4.875	4.483	4.874	0.130	0.115	-156
MFP-TPS-500	5.000	4.608	4.999	0.130	0.115	-157
MFP-TPS-525	5.250	4.858	5.249	0.130	0.115	-158
MFP-TPS-550	5.500	5.108	5.499	0.130	0.115	-159
TOLERANCE	H9	h9	h9	+0.003/-0.003	+0.002/-0.002	
MFP-TPS-575	5.750	5.232	5.748	0.160	0.143	-251
MFP-TPS-587	5.875	5.357	5.873	0.160	0.143	-252
MFP-TPS-600	6.000	5.482	5.998	0.160	0.143	-253
MFP-TPS-612	6.125	5.607	6.123	0.160	0.143	-254
MFP-TPS-625	6.250	5.732	6.248	0.160	0.143	-255
MFP-TPS-650	6.500	5.982	6.498	0.160	0.143	-257
MFP-TPS-675	6.750	6.232	6.748	0.160	0.143	-258
MFP-TPS-700	7.000	6.482	6.998	0.160	0.143	-259
MFP-TPS-712	7.125	6.607	7.123	0.160	0.143	-260
MFP-TPS-725	7.250	6.732	7.248	0.160	0.143	-260
MFP-TPS-750	7.500	6.982	7.498	0.160	0.143	-261
MFP-TPS-775	7.750	7.232	7.748	0.160	0.143	-262
MFP-TPS-800	8.000	7.482	7.998	0.160	0.143	-263
MFP-TPS-812	8.125	7.607	8.123	0.160	0.143	-264
MFP-TPS-825	8.250	7.732	8.248	0.160	0.143	-264
MFP-TPS-850	8.500	7.982	8.498	0.160	0.143	-265

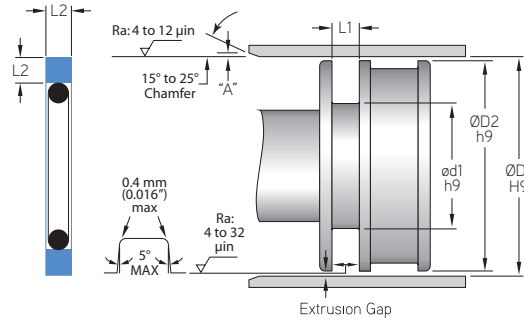

TPS - T1075N

MFP PART NUMBER	PISTON APPLICATION					O-Ring DASH NO.
	ØD1	ød1	ØD2	L1	L2	
TOLERANCE	H9	h9	h9	+0.003/-0.003	+0.002/-0.002	
MFP-TPS-875	8.750	8.232	8.748	0.160	0.143	-266
MFP-TPS-900	9.000	8.482	8.998	0.160	0.143	-267
MFP-TPS-925	9.250	8.732	9.248	0.160	0.143	-268
MFP-TPS-950	9.500	8.982	9.498	0.160	0.143	-269
MFP-TPS-975	9.750	9.232	9.748	0.160	0.143	-270
MFP-TPS-1000	10.000	9.482	9.998	0.160	0.143	-271
MFP-TPS-1025	10.250	9.732	10.248	0.160	0.143	-272
MFP-TPS-1050	10.500	9.982	10.498	0.160	0.143	-273
MFP-TPS-1075	10.750	10.232	10.748	0.160	0.143	-274
MFP-TPS-1100	11.000	10.482	10.998	0.160	0.143	-275
MFP-TPS-1150	11.500	10.982	11.498	0.160	0.143	-276
MFP-TPS-1200	12.000	11.482	11.998	0.160	0.143	-277
MFP-TPS-1250	12.500	11.982	12.498	0.160	0.143	-278
MFP-TPS-1300	13.000	12.482	12.998	0.160	0.143	-278
MFP-TPS-1400	14.000	13.482	13.998	0.160	0.143	-279
MFP-TPS-1500	15.000	14.482	14.998	0.160	0.143	-280
MFP-TPS-1600	16.000	15.482	15.998	0.160	0.143	-281

PISTON ASSEMBLIES