



**TPM - MIDSIZE RING (2 PC.) PISTON SEAL**

TPM PTFE rings are a rectangular series of piston rings which fill the gap between our square and rectangular series. Our filled PTFE, with its low coefficient of friction, will reduce frictional heat while the O-Ring expander creates an effective compression seal.

O-Rings expanders are provided with each ring.



**This seal is available in Filled PTFE: T1075, T1125, and T5100, with an N6001, V7100 or V7155 O-Ring Expander.**

*For increased chemical and temperature resistance, other compounds are available (See pages 20-37).*

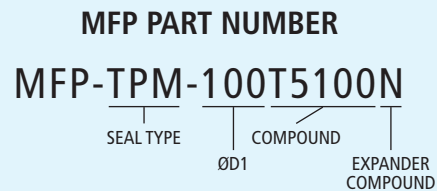
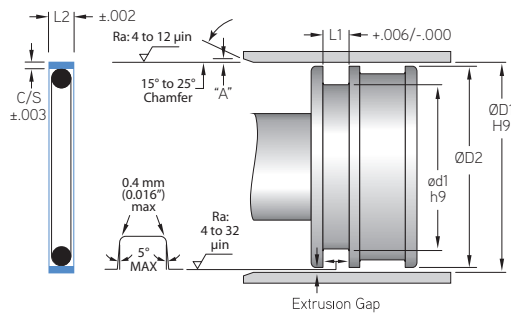

**Pressure: 250 bar (3,625 psi)**

**Max. Velocity: 4.0 m/s (13 ft./s)**

MFP PART NUMBER	PISTON APPLICATION					
	ØD1	ød1	L1	L2	C/S	EXPANDER
TOLERANCE	H9	h9	+0.006/-0.000	+0.002/-0.002	+0.003/-0.003	
MFP-TPM-100	1.000	.787	.094	.090	.058	OR-018
MFP-TPM-112	1.125	.912	.094	.090	.058	OR-020
MFP-TPM-125	1.250	1.037	.094	.090	.058	OR-022
MFP-TPM-137	1.375	1.162	.094	.090	.058	OR-024
MFP-TPM-150	1.500	1.287	.094	.090	.058	OR-026
MFP-TPM-162	1.625	1.412	.094	.090	.058	OR-028
MFP-TPM-175-0	1.750	1.537	.094	.090	.058	OR-030
MFP-TPM-175	1.750	1.473	.126	.122	.062	OR-127
MFP-TPM-187	1.875	1.598	.126	.122	.062	OR-129
MFP-TPM-200	2.000	1.723	.126	.122	.062	OR-131
MFP-TPM-225	2.250	1.937	.126	.122	.062	OR-135
MFP-TPM-237	2.375	2.098	.126	.122	.062	OR-137
MFP-TPM-250	2.500	2.223	.126	.122	.062	OR-139
MFP-TPM-275	2.750	2.348	.157	.152	.092	OR-229
MFP-TPM-300	3.000	2.603	.157	.152	.092	OR-231
MFP-TPM-325	3.250	2.853	.157	.152	.092	OR-233
MFP-TPM-350	3.500	3.103	.157	.152	.092	OR-235
MFP-TPM-375	3.750	3.353	.157	.152	.092	OR-237
MFP-TPM-400	4.000	3.603	.157	.152	.092	OR-239
MFP-TPM-425	4.250	3.853	.157	.152	.092	OR-241



# TPM - Midsize Ring (2 PC.) Piston Seal

A product of MFP Seals.

**MFPSEALS**  
www.mfpseals.com

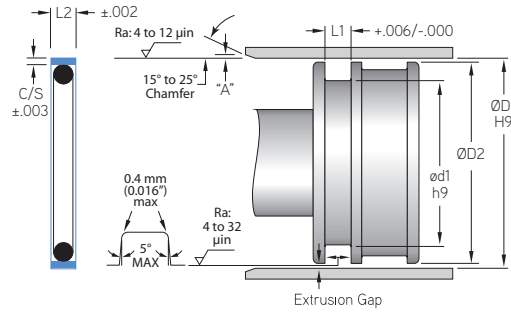

TPM - T5100N

PISTON ASSEMBLIES

MFP PART NUMBER	PISTON APPLICATION					EXPANDER
	ØD1	ød1	L1	L2	C/S	
<b>TOLERANCE</b>	H9	h9	+0.006/-0.000	+0.002/-0.002	+0.003/-0.003	
MFP-TPM-450	4.500	4.103	.157	.152	.092	OR-243
MFP-TPM-475	4.750	4.353	.157	.152	.092	OR-245
MFP-TPM-500	5.000	4.603	.157	.152	.092	OR-247
MFP-TPM-525	5.250	4.853	.157	.152	.092	OR-249
MFP-TPM-550	5.500	5.103	.157	.152	.092	OR-251
MFP-TPM-575	5.750	5.353	.157	.152	.092	OR-253
MFP-TPM-600	6.000	5.350	.293	.272	.122	OR-355
MFP-TPM-700	7.000	6.350	.293	.272	.122	OR-362