



RS11 - (2 P.C.) ROTARY PISTON SEAL

MFP Seals' RS11 rotary piston seal is used in light to medium duty oscillating applications. The RS11 design is ideal because of its low friction and long wear capabilities.



The standard compound for this seal is T5100 Piston Seal, with an N6001 O-Ring expander.

For increased chemical and temperature resistance, other compounds are available (See pages 20-37).

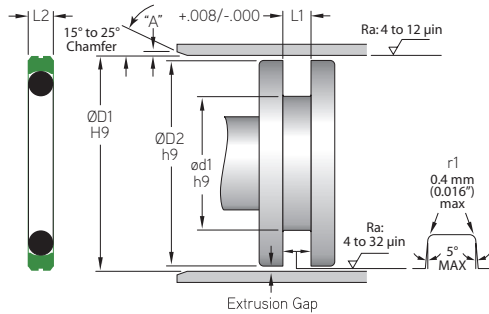

MFP PART NUMBER

RS11-0375x0T5100N

SEAL TYPE ØD1 EXPANDER SERIES COMPOUND EXPANDER COMPOUND

Pressure: 200 bar (3,000 psi) Max. Velocity: 1.0 m/s (3 ft./s)

MFP PART NUMBER	PISTON APPLICATION				O-Ring DASH NO.
	ØD1	ød1	L1	ØD2	
TOLERANCE	H9	h9	+0.008/-0.000	h9	
RS11-0500X0	0.500	0.307	0.087	0.499	-011
RS11-0563X0	0.563	0.370	0.087	0.562	-012
RS11-0625X0	0.625	0.432	0.087	0.624	-013
RS11-0688X0	0.688	0.495	0.087	0.687	-014
RS11-0750X0	0.750	0.557	0.087	0.749	-015
RS11-0813X0	0.813	0.620	0.087	0.812	-016
RS11-0875X0	0.875	0.682	0.087	0.874	-017
RS11-0937X0	0.938	0.745	0.087	0.937	-018
RS11-1000X0	1.000	0.807	0.087	0.999	-019
RS11-1125X0	1.125	0.932	0.087	1.124	-021
RS11-1250X0	1.250	1.057	0.087	1.249	-023
RS11-1375X0	1.375	1.182	0.087	1.374	-025
RS11-1500X1	1.500	1.205	0.126	1.499	-123
RS11-1625X1	1.625	1.330	0.126	1.624	-125
RS11-1750X1	1.750	1.455	0.126	1.749	-127
RS11-1875X1	1.875	1.580	0.126	1.874	-129
RS11-2000X1	2.000	1.705	0.126	1.999	-131
RS11-2125X1	2.125	1.830	0.126	2.124	-133
RS11-2250X1	2.250	1.955	0.126	2.249	-135
RS11-2375X1	2.375	2.080	0.126	2.374	-137
RS11-2500X1	2.500	2.205	0.126	2.499	-139
RS11-2625X1	2.625	2.330	0.126	2.624	-141
RS11-2750X1	2.750	2.455	0.126	2.749	-143
RS11-2875X1	2.875	2.580	0.126	2.874	-145

RS11

PISTON ASSEMBLIES



RS11 - (2 PC.) Rotary Piston Seal

A product of MFP Seals.

MFPSEALS

www.mfpseals.com

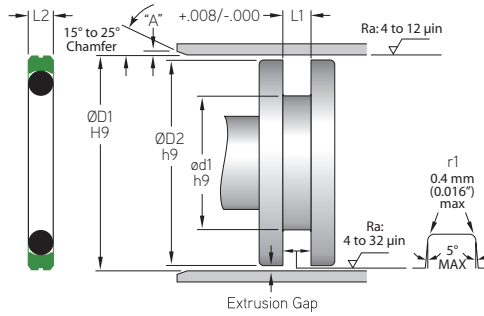

RS11

PISTON ASSEMBLIES

MFP PART NUMBER	PISTON APPLICATION				O-Ring DASH NO.
	ØD1	ød1	L1	ØD2	
TOLERANCE	H9	h9	+0.008/-0.000	h9	
RS11-3000X2	3.000	2.567	0.165	2.999	-230
RS11-3125X2	3.125	2.692	0.165	3.124	-231
RS11-3250X2	3.250	2.817	0.165	3.249	-232
RS11-3375X2	3.375	2.942	0.165	3.374	-233
RS11-3500X2	3.500	3.067	0.165	3.499	-234
RS11-3625X2	3.625	3.192	0.165	3.624	-235
RS11-3750X2	3.750	3.317	0.165	3.749	-236
RS11-3875X2	3.875	3.442	0.165	3.874	-237
RS11-4000X2	4.000	3.567	0.165	3.999	-238
RS11-4125X2	4.125	3.692	0.165	4.124	-239
RS11-4250X2	4.250	3.817	0.165	4.249	-240
RS11-4375X2	4.375	3.942	0.165	4.374	-241
RS11-4500X2	4.500	4.067	0.165	4.499	-242
RS11-4625X2	4.625	4.192	0.165	4.624	-243
RS11-4750X2	4.750	4.317	0.165	4.749	-244
RS11-4875X2	4.875	4.442	0.165	4.874	-245
RS11-5000X2	5.000	4.567	0.165	4.999	-246
RS11-5125X2	5.125	4.692	0.165	5.124	-247
RS11-5250X2	5.250	4.817	0.165	5.249	-248
RS11-5375X2	5.375	4.942	0.165	5.374	-249
RS11-5500X2	5.500	5.067	0.165	5.499	-250
RS11-5625X2	5.625	5.192	0.165	5.624	-251
RS11-5750X2	5.750	5.317	0.165	5.749	-252
RS11-5875X2	5.875	5.442	0.165	5.874	-253
RS11-6000X3	6.000	5.390	0.248	5.999	-355
RS11-6250X3	6.250	5.640	0.248	6.249	-357
RS11-6500X3	6.500	5.890	0.248	6.499	-359
RS11-6750X3	6.750	6.140	0.248	6.749	-361
RS11-7000X3	7.000	6.390	0.248	6.999	-362
RS11-7250X3	7.250	6.640	0.248	7.248	-363
RS11-7500X3	7.500	6.890	0.248	7.498	-364
RS11-7750X3	7.750	7.140	0.248	7.748	-365
RS11-8000X3	8.000	7.390	0.248	7.998	-366
RS11-8250X3	8.250	7.640	0.248	8.248	-367
RS11-8500X3	8.500	7.890	0.248	8.498	-368

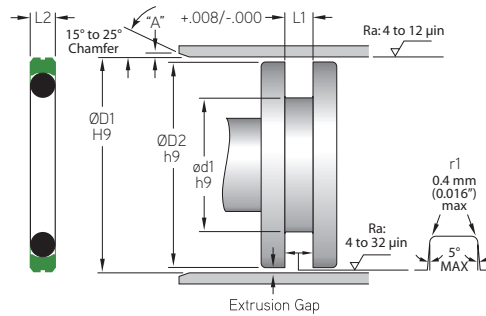

RS11

MFP PART NUMBER	PISTON APPLICATION				O-Ring DASH NO.
	ØD1	ød1	L1	ØD2	
TOLERANCE	H9	h9	+.008/-0.000	h9	
RS11-8750X3	8.750	8.140	0.248	8.748	-369
RS11-9000X3	9.000	8.390	0.248	8.998	-370
RS11-9250X3	9.250	8.640	0.248	9.248	-371
RS11-9500X3	9.500	8.890	0.248	9.498	-372
RS11-9750X3	9.750	9.140	0.248	9.748	-373
RS11-10000X3	10.000	9.390	0.248	9.998	-374
RS11-10500X3	10.500	9.890	0.248	10.498	-376
RS11-11000X3	11.000	10.390	0.248	10.998	-377
RS11-11500X3	11.500	10.890	0.248	11.498	-378
RS11-12000X4	12.000	11.173	0.319	11.998	-451
RS11-12500X4	12.500	11.673	0.319	12.498	-452
RS11-13000X4	13.000	12.173	0.319	12.998	-453
RS11-13500X4	13.500	12.673	0.319	13.498	-454
RS11-14000X4	14.000	13.173	0.319	13.998	-455
RS11-14500X4	14.500	13.673	0.319	14.498	-456
RS11-15000X4	15.000	14.173	0.319	14.998	-457
RS11-15500X4	15.500	14.673	0.319	15.498	-458
RS11-16000X4	16.000	15.173	0.319	15.998	-459
RS11-16500X4	16.500	15.673	0.319	16.498	-460
RS11-17000X4	17.000	16.173	0.319	16.998	-461
RS11-17500X4	17.500	16.673	0.319	17.498	-462
RS11-18000X4	18.000	17.173	0.319	17.998	-463
RS11-18500X4	18.500	17.673	0.319	18.498	-464
RS11-19000X4	19.000	18.173	0.319	18.998	-465
RS11-19500X4	19.500	18.673	0.319	19.498	-466
RS11-20000X4	20.000	19.173	0.319	19.998	-467

PISTON ASSEMBLIES