



HPX Piston Seal™ - (2 P.C.)

A product of MFP Seals.

MFPSEALS
www.mfpseals.com

HPX PISTON SEAL™

HPX PISTON SEAL™ - (2 P.C.)

MFP Seals' compact HPX Piston Seal™ is designed to fit AS568 standard O-Ring grooves. The HPX seal is composed of a Hytrel® seal with an NBR elastomeric energizer, design for light to medium duty hydraulic applications.



The standard compound for this seal is H2155, with an NBR expander. It is also available in U2150, with an NBR expander.

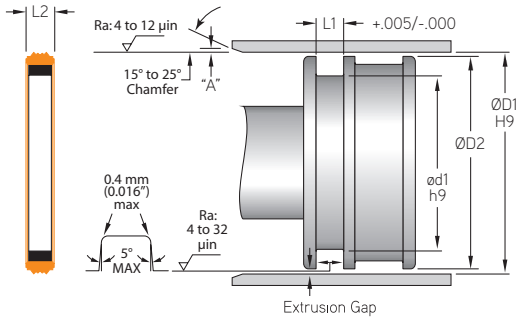

MFP PART NUMBER
HPX-218H2155
SEAL TYPE SIZE PER O-Ring DASH COMPOUND

Pressure: 350 bar (5,000 psi)

Max. Velocity: 1.0 m/s (3 ft./s)

FITS STANDARD AS568 O-RING GROOVE

MFP PART NUMBER	ØD1	ØD2	ød1	L1
TOLERANCE	H9	h9	h9	+0.005/-0.000
HPX-218	1.500	1.498	1.258	0.187
HPX-222	1.750	1.748	1.508	0.187
HPX-326	2.000	1.998	1.630	0.281
HPX-330	2.500	2.498	2.130	0.281
HPX-334	3.000	2.998	2.630	0.281
HPX-338	3.500	3.498	3.130	0.281
HPX-342	4.000	3.998	3.630	0.281
HPX-350	5.000	4.998	4.630	0.281

FITS O-RING GROOVE DESIGNED FOR TWO BACK-UP RINGS

MFP PART NUMBER	ØD1	ØD2	ød1	L1
TOLERANCE	H9	h9	h9	+0.005/-0.000
HPX-218-2	1.500	1.498	1.258	0.275
HPX-326-2	2.000	1.998	1.630	0.410
HPX-330-2	2.500	2.498	2.130	0.410
HPX-334-2	3.000	2.998	2.630	0.410
HPX-338-2	3.500	3.498	3.130	0.410
HPX-342-2	4.000	3.998	3.630	0.410
HPX-425-2	5.000	4.998	4.528	0.538
HPX-433-2	6.000	5.998	5.528	0.538

PISTON ASSEMBLIES