

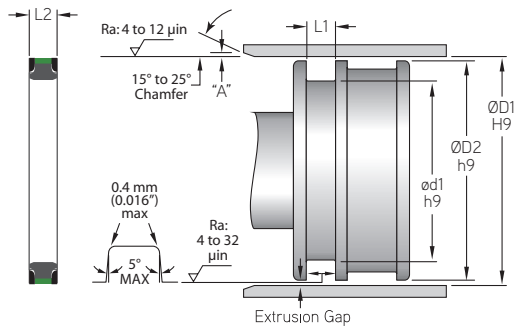

NCGT

**NARROW CAPPED GT - (4 PC.) PISTON SEAL**

Narrow Capped GT Rings are a heavy duty double-acting assembly. They are designed the same as Capped GT Rings, but are made to special sizes found in OEM cylinders, including Caterpillar®. Each piston set consists of a rubber expander, filled PTFE seal, and two Nylon® anti-extrusion rings. Narrow Capped GT Rings have excellent sealability; extrusion and wear resistance.

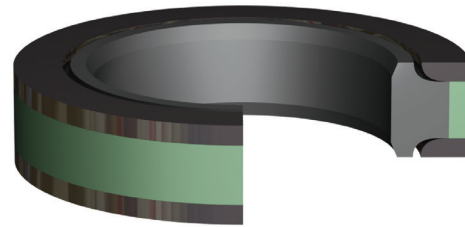

**MFP PART NUMBER**

**NCGT-450N6023/T5100A**

SEAL TYPE	SIZE	EXPANDER COMPOUND	CAP COMPOUND	BACK-UP RING COMPOUND A = M1001
-----------	------	-------------------	--------------	------------------------------------

*Energizer - N6001, N6015, N6021, N6022 & N6023*  
*Cap - T5100*  
*Back-Up Rings - M1001*

**Pressure: 500 bar (7,500 psi)**

**Max. Velocity: 1.5 m/s (5 ft./s)**

MFP PART NUMBER	PISTON APPLICATION			
	ØD1	ØD2	ød1	L1
TOLERANCE	H9	h9	h9	
NCGT-450	4.500	4.497	3.909	0.492
NCGT-500	5.000	4.996	4.094	0.630
NCGT-550	5.500	5.496	4.594	0.630
NCGT-600	6.000	5.996	5.094	0.630
NCGT-625	6.250	6.246	5.344	0.630
NCGT-650	6.500	6.496	5.594	0.630
NCGT-700	7.000	6.996	6.094	0.630
NCGT-725	7.250	7.246	6.344	0.630
NCGT-750	7.500	7.496	6.594	0.630
NCGT-775	7.750	7.746	6.844	0.630
NCGT-825	8.250	8.246	7.344	0.630
NCGT-850	8.500	8.496	7.594	0.630
NCGT-1000	10.000	9.996	8.898	0.689
NCGT-1050	10.500	10.496	9.398	0.689
NCGT-1150	11.500	11.496	10.398	0.689

PISTON ASSEMBLIES