

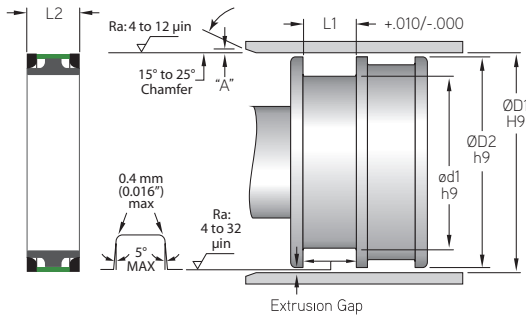

CGT

CAPPED GT - (4 PC.) PISTON SEAL

Capped GT Rings are a heavy duty double-acting assembly. Each piston set consists of a rubber expander, filled PTFE Seal, and two Nylon® anti-extrusion rings. Capped GT Rings have excellent sealability; extrusion and wear resistance.

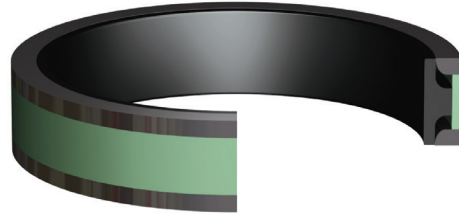

MFP PART NUMBER

CGT-300N6023/T5100A

SEAL TYPE	SIZE	EXPANDER COMPOUND	CAP COMPOUND	BACK-UP RING COMPOUND
				A = M1001

Energizer - N6001, N6015, N6021, N6022 & N6023
Cap - T5100
Back-Up Rings - M1001

Pressure: 500 bar (7,500 psi)

Max. Velocity: 1.5 m/s (5 ft./s)

MFP PART NUMBER	PISTON APPLICATION			
	ØD1	ØD2	ød1	L1
TOLERANCE	H9	h9	h9	+.010/-0.000
CGT-100	1.000	0.999	0.628	0.424
CGT-150	1.500	1.499	1.128	0.424
CGT-175	1.750	1.749	1.378	0.424
CGT-200	2.000	1.999	1.628	0.424
CGT-225	2.250	2.249	1.878	0.424
CGT-250	2.500	2.499	2.128	0.424
CGT-275	2.750	2.749	2.378	0.424
CGT-300	3.000	2.998	2.522	0.579
CGT-325	3.250	3.248	2.772	0.579
CGT-350	3.500	3.498	3.022	0.579
CGT-375	3.750	3.748	3.272	0.579
CGT-400	4.000	3.998	3.522	0.579
CGT-425	4.250	4.248	3.772	0.579
CGT-450	4.500	4.498	4.022	0.579
CGT-475	4.750	4.748	4.272	0.579
CGT-500	5.000	4.998	4.272	0.750
CGT-525	5.250	5.248	4.522	0.750
CGT-537	5.375	5.373	4.647	0.750
CGT-550	5.500	5.497	4.772	0.750
CGT-555	5.500	5.497	5.020	0.579
CGT-575	5.750	5.747	5.022	0.750
CGT-600	6.000	5.997	5.272	0.750

PISTON ASSEMBLIES



Capped GT - (4 PC.) Piston Seal

A product of MFP Seals.

MFPSEALS

www.mfpseals.com

CGT

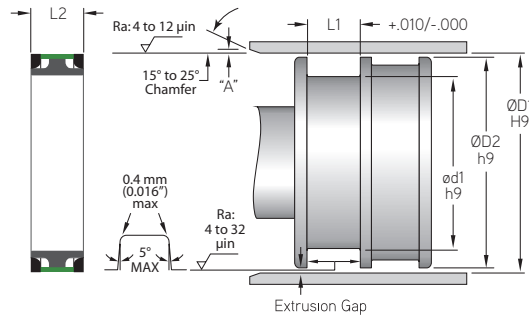

PISTON ASSEMBLIES

MFP PART NUMBER	PISTON APPLICATION			
	ØD1	ØD2	ød1	L1
TOLERANCE	H9	h9	h9	+.010/-0.000
CGT-625	6.250	6.247	5.522	0.750
CGT-650	6.500	6.497	5.772	0.750
CGT-655	6.500	6.497	6.020	0.579
CGT-675	6.750	6.747	6.022	0.750
CGT-700	7.000	6.997	6.272	0.750
CGT-725	7.250	7.247	6.522	0.750
CGT-750	7.500	7.497	6.772	0.750
CGT-775	7.750	7.747	7.022	0.750
CGT-800	8.000	7.996	7.272	0.750
CGT-825	8.250	8.246	7.522	0.750
CGT-850	8.500	8.496	7.772	0.750
CGT-875	8.750	8.746	8.022	0.750
CGT-900	9.000	8.996	8.272	0.750
CGT-950	9.500	9.496	8.772	0.750
CGT-1000	10.000	9.996	9.272	0.750
CGT-1050	10.500	10.496	9.772	0.750
CGT-1100	11.000	10.996	10.272	0.750
CGT-1150	11.500	11.496	10.772	0.750
CGT-1200	12.000	11.996	11.272	0.750
CGT-1250	12.500	12.496	11.772	0.750
CGT-1300	13.000	12.996	12.272	0.750
CGT-1350	13.500	13.495	12.772	0.750
CGT-1400	14.000	13.995	13.272	0.750
CGT-1500	15.000	14.995	14.272	0.750
CGT-1600	16.000	15.995	15.272	0.750