

# PCF - Fabric & Rubber Piston Cup

A product of MFP Seals.

PCF

## PCF - FABRIC & RUBBER PISTON CUP

Fabric & Rubber Piston Cups prevent extrusion in medium pressure installations under 1,000 PSI. There is less chance of overtightening the inside follower plate, which can be a problem with rubber cups. All Fabric & Rubber Cups are supplied solid, with no precut hole.

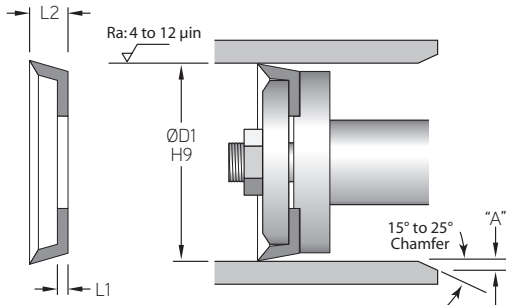
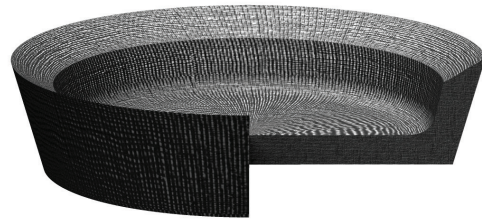

### MFP PART NUMBER

**PCF-175M1009**

SEAL TYPE      ØD1      COMPOUND

**M1009 - FABRIC & RUBBER**

PISTON CUPS

MFP PART NUMBER	ØD1	PISTON APPLICATION	
		L1	L2
<b>TOLERANCE</b>	H9		
PCF-050	0.500	0.125	0.500
PCF-075	0.750	0.125	0.500
PCF-087	0.875	0.094	0.375
PCF-093	0.938	0.125	0.500
PCF-100	1.000	0.125	0.500
PCF-112	1.125	0.125	0.500
PCF-125	1.250	0.125	0.500
PCF-137	1.375	0.125	0.500
PCF-150	1.500	0.125	0.500
PCF-162	1.625	0.125	0.500
PCF-175	1.750	0.125	0.500
PCF-187	1.875	0.125	0.500
PCF-200	2.000	0.125	0.500
PCF-212	2.125	0.125	0.500
PCF-225	2.250	0.125	0.500
PCF-237	2.375	0.125	0.500
PCF-250	2.500	0.125	0.500
PCF-262	2.625	0.125	0.500
PCF-275	2.750	0.125	0.500
PCF-287	2.875	0.125	0.500
PCF-300	3.000	0.156	0.625
PCF-312	3.125	0.156	0.625
PCF-325	3.250	0.156	0.625
PCF-337	3.375	0.156	0.625

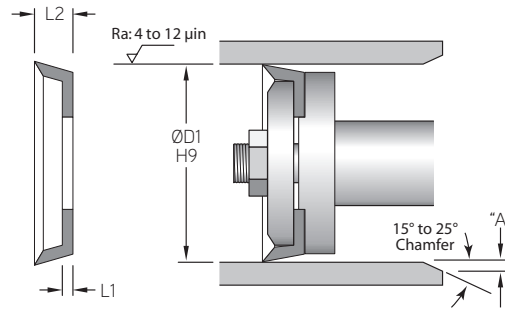

PCF

MFP PART NUMBER	PISTON APPLICATION		
	ØD1	L1	L2
<b>TOLERANCE</b>	H9		
PCF-350	3.500	0.156	0.625
PCF-362	3.625	0.156	0.625
PCF-375	3.750	0.156	0.750
PCF-387	3.875	0.156	0.625
PCF-400	4.000	0.156	0.625
PCF-425	4.250	0.156	0.625
PCF-450	4.500	0.156	0.625
PCF-462	4.625	0.156	0.625
PCF-475	4.750	0.156	0.625
PCF-487	4.875	0.156	0.625
PCF-500	5.000	0.188	0.750
PCF-525	5.250	0.188	0.750
PCF-550	5.500	0.188	0.750
PCF-575	5.750	0.188	0.750
PCF-587	5.875	0.188	0.750
PCF-600	6.000	0.188	0.750
PCF-625	6.250	0.188	0.750
PCF-637	6.375	0.188	0.750
PCF-650	6.500	0.188	0.750
PCF-675	6.750	0.188	0.750
PCF-700	7.000	0.188	0.750
PCF-725	7.250	0.188	1.000
PCF-750	7.500	0.188	1.000
PCF-800	8.000	0.188	1.000
PCF-850	8.500	0.188	1.000
PCF-900	9.000	0.188	0.750
PCF-950	9.500	0.188	1.000
PCF-975	9.750	0.188	1.000
PCF-1000	10.000	0.188	1.000
PCF-1025	10.250	0.188	1.000
PCF-1100	11.000	0.188	1.000
PCF-1200	12.000	0.188	1.000
PCF-1225	12.250	0.188	1.000
PCF-1400	14.000	0.250	1.250
PCF-1600	16.000	0.250	1.500

PISTON CUPS