

MWRP - TIGHT TOLERANCE METRIC GUIDE RINGS - C1000

MFP Seals' Tight Tolerance MWRP are made from a fine weave cotton fabric and reinforced with phenolic composites. This design totally eliminates metal to metal contact and the consequent galling and scoring of cylinder bores. Wear rings are supplied butt cut or scarf cut, for easy installation, and are a low maintenance solution. Typical uses are as hydraulic cylinder wear rings, sliding bearings, bushings, or thrust bearings.

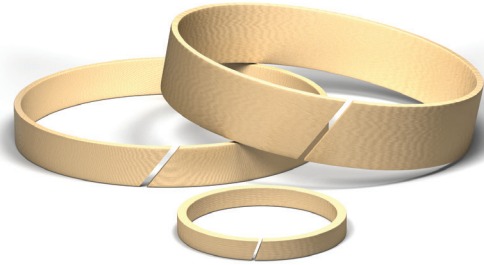

For sizes not listed please contact your MFP Seals' Sales Representative.

TEMP RANGE: -40°C TO 130°C (-40°F TO 266°F)

MAX. LOAD: 270 MPA (STATIC), 54 MPA (DYNAMIC)

MAX. PV FACTOR: 0.2 MPA X M/S (DRY)
0.38 MPA X M/S (OIL LUBRICATED)
0.60 MPA X M/S (GREASED)

FRICTIONAL COEFFICIENT: 0.13~0.17 (DRY)

MFP PART NUMBER

MWRP-040x09.5x2.5C1000

SEAL TYPE ØD1 L1 C/S COMPOUND

Max. Velocity: 2.2 m/s (7.2 ft./s)

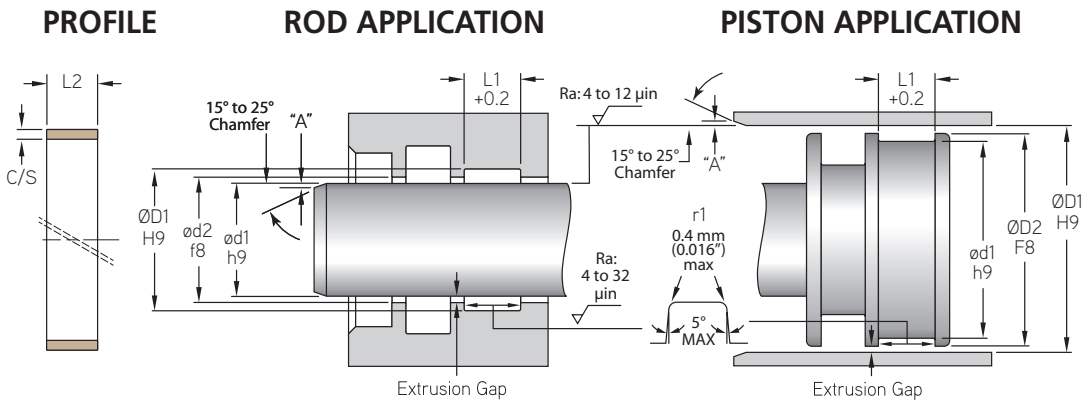

INSTALLATION RECOMMENDATIONS

PISTON			ROD		
Bore Diameter	Groove Width	Ring Thickness	Rod Diameter	Groove Width	Ring Thickness
ØD1 (H9)	L1 (+0.2)	C/S	Ød1 (f8/h9)	L1 (+0.2)	C/S
16 - 50.0	4.00	1.55	8 - 50.0	4.00	1.55
16 - 125.0	5.60	2.50	16 - 120.0	5.60	2.50
25 - 250.0	9.70	2.50	25 - 250.0	9.70	2.50
80 - 500.0	15.00	2.50	75 - 500.0	15.00	2.50
125 - 999.9	25.00	2.50	120 - 999.9	25.00	2.50
1000 - 1500.0	25.00	2.50	1000 - 1500.0	25.00	2.50
280 - 999.9	25.00	4.00	280 - 999.9	25.00	4.00
1000 - 1500.0	25.00	4.00	1000 - 1500.0	25.00	4.00

MWRP - Tight Tolerance Metric Guide Ring - C1000

A product of MFP Seals.

MFPSEALS
www.mfpseals.com

MWRP

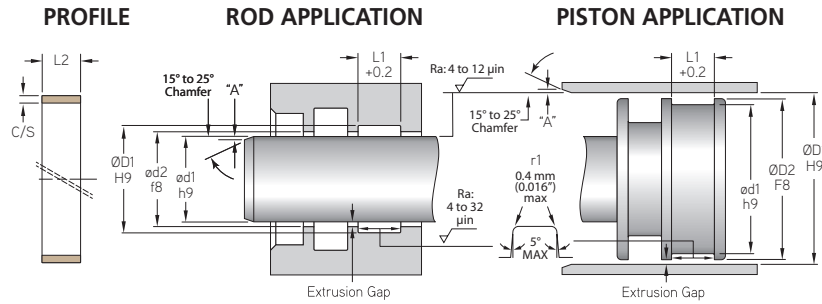

MFP PART NUMBER	ROD OR PISTON APPLICATION			
	ØD1	ød1	L1	C/S
TOLERANCE	H9	h9	+0.2	
MWRP-022X8.0X2.0	22	18	8	2
MWRP-025X3.8X1.5	25	22	3.8	1.5
MWRP-025X8.0X2.0	25	21	8	2
MWRP-026X8.0X2.0	26	22	8	2
MWRP-026X15.0X2.0	26	22	15	2
MWRP-029X8.0X2.0	29	25	8	2
MWRP-029X20.0X2.0	29	25	20	2
MWRP-029X25.0X2.0	29	25	25	2
MWRP-030X8.0X2.0	30	26	8	2
MWRP-030X8.0X2.5	30	25	8	2.5
MWRP-030X9.5X2.5	30	25	9.5	2.5
MWRP-030X15.0X2.5	30	25	15	2.5
MWRP-030X20.0X2.5	30	25	20	2.5
MWRP-031X16.0X1.5	31	28	16	1.5
MWRP-032X8.0X2.0	32	28	8	2
MWRP-032X20.0X2.0	32	28	20	2
MWRP-033X20.0X2.5	33	28	20	2.5
MWRP-034X10.0X2.0	34	30	10	2
MWRP-034X20.0X2.0	34	30	20	2
MWRP-034X25.0X2.0	34	30	25	2
MWRP-035X10.0X2.0	35	31	10	2
MWRP-035X9.5X2.5	35	30	9.5	2.5
MWRP-035X10.0X2.5	35	30	10	2.5
MWRP-035X20.0X2.5	35	30	20	2.5
MWRP-035X25.0X2.5	35	30	25	2.5
MWRP-035X30.0X2.5	35	30	30	2.5
MWRP-036X10.0X2.0	36	32	10	2
MWRP-036X20.0X2.0	36	32	20	2
MWRP-036X6.0X2.5	36	31	6	2.5
MWRP-038X6.0X3.0	38	32	6	3
MWRP-039X10.0X2.0	39	35	10	2
MWRP-039X25.0X2.0	39	35	25	2
MWRP-040X8.0X2.0	40	36	8	2
MWRP-040X10.0X2.0	40	36	10	2
MWRP-040X20.0X2.0	40	36	20	2
MWRP-040X9.5X2.5	40	35	9.5	2.5
MWRP-040X15.0X2.5	40	35	15	2.5

METRIC WEAR RINGS

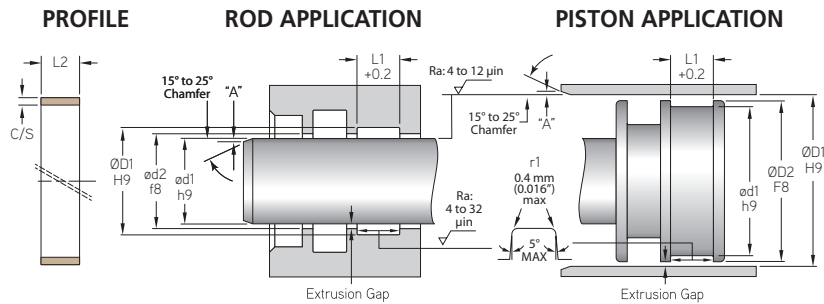

MFP PART NUMBER	ROD OR PISTON APPLICATION			
	ØD1	ød1	L1	C/S
TOLERANCE	H9	h9	+0.2	
MWRP-040X5.0X5.0	40	30	5	5
MWRP-041X9.7X3.0	41	35	9.7	3
MWRP-045X12.0X2.0	45	41	12	2
MWRP-045X20.0X2.0	45	41	20	2
MWRP-045X5.6X2.5	45	40	5.6	2.5
MWRP-045X9.5X2.5	45	40	9.5	2.5
MWRP-045X10.0X2.5	45	40	10	2.5
MWRP-045X15.0X2.5	45	40	15	2.5
MWRP-045X20.0X2.5	45	40	20	2.5
MWRP-045X5.0X3.0	45	39	5	3
MWRP-045X14.0X3.0	45	39	14	3
MWRP-045X14.5X3.0	45	39	14.5	3
MWRP-045X15.0X3.0	45	39	15	3
MWRP-046X20.0X3.0	46	40	20	3
MWRP-046X25.0X3.0	46	40	25	3
MWRP-048X22.5X1.5	48	45	22.5	1.5
MWRP-049X8.0X2.0	49	45	8	2
MWRP-049X14.5X2.0	49	45	14.5	2
MWRP-049X15.0X2.0	49	45	15	2
MWRP-049X25.0X2.0	49	45	25	2
MWRP-050X8.0X2.0	50	46	8	2
MWRP-050X9.7X2.0	50	46	9.7	2
MWRP-050X10.0X2.0	50	46	10	2
MWRP-050X12.0X2.0	50	46	12	2
MWRP-050X14.5X2.0	50	46	14.5	2
MWRP-050X15.0X2.0	50	46	15	2
MWRP-050X20.0X2.0	50	46	20	2
MWRP-050X5.0X2.5	50	45	5	2.5
MWRP-050X5.6X2.5	50	45	5.6	2.5
MWRP-050X6.3X2.5	50	45	6.3	2.5
MWRP-050X6.8X2.5	50	45	6.8	2.5
MWRP-050X8.0X2.5	50	45	8	2.5
MWRP-050X9.5X2.5	50	45	9.5	2.5
MWRP-050X10.0X2.5	50	45	10	2.5
MWRP-050X12.0X2.5	50	45	12	2.5
MWRP-050X15.0X2.5	50	45	15	2.5
MWRP-050X20.0X2.5	50	45	20	2.5

MWRP - Tight Tolerance Metric Guide Ring - C1000

A product of MFP Seals.

MFPSEALS
www.mfpseals.com

MWRP

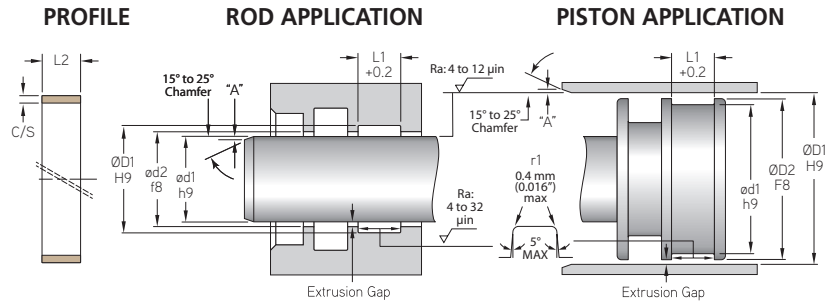

MFP PART NUMBER	ROD OR PISTON APPLICATION			
	ØD1	ød1	L1	C/S
TOLERANCE	H9	h9	+0.2	
MWRP-050X25.0X2.5	50	45	25	2.5
MWRP-050X30.0X2.5	50	45	30	2.5
MWRP-050X35.0X2.5	50	45	35	2.5
MWRP-050X8.0X3.0	50	44	8	3
MWRP-051X22.5X2.5	51	46	22.5	2.5
MWRP-051X22.5X3.0	51	45	22.5	3
MWRP-051X38.0X3.0	51	45	38	3
MWRP-052X8.0X1.5	52	49	8	1.5
MWRP-053X8.0X1.5	53	50	8	1.5
MWRP-053X12.0X1.5	53	50	12	1.5
MWRP-055X10.0X2.0	55	51	10	2
MWRP-055X8.0X2.5	55	50	8	2.5
MWRP-055X9.5X2.5	55	50	9.5	2.5
MWRP-055X9.7X2.5	55	50	9.7	2.5
MWRP-055X10.0X2.5	55	50	10	2.5
MWRP-055X15.0X2.5	55	50	15	2.5
MWRP-055X20.0X2.5	55	50	20	2.5
MWRP-055X25.0X2.5	55	50	25	2.5
MWRP-055X30.0X2.5	55	50	30	2.5
MWRP-055X6.0X3.0	55	49	6	3
MWRP-055X15.0X3.0	55	49	15	3
MWRP-055X15.5X3.0	55	49	15.5	3
MWRP-055X20.0X3.0	55	49	20	3
MWRP-056X10.0X2.5	56	51	10	2.5
MWRP-056X15.0X2.5	56	51	15	2.5
MWRP-056X10.0X3.0	56	50	10	3
MWRP-056X16.0X3.0	56	50	16	3
MWRP-056X25.0X3.0	56	50	25	3
MWRP-056X28.0X3.0	56	50	28	3
MWRP-056X30.0X3.0	56	50	30	3
MWRP-060X25.0X2.0	60	56	25	2
MWRP-060X5.5X2.5	60	55	5.5	2.5
MWRP-060X8.0X2.5	60	55	8	2.5
MWRP-060X9.5X2.5	60	55	9.5	2.5
MWRP-060X9.7X2.5	60	55	9.7	2.5
MWRP-060X10.0X2.5	60	55	10	2.5
MWRP-060X14.5X2.5	60	55	14.5	2.5

METRIC WEAR RINGS

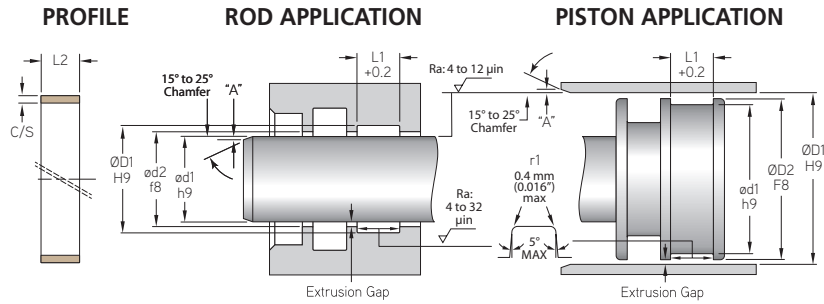

MFP PART NUMBER	ROD OR PISTON APPLICATION			
	ØD1	ød1	L1	C/S
TOLERANCE	H9	h9	+0.2	
MWRP-060X15.0X2.5	60	55	15	2.5
MWRP-060X20.0X2.5	60	55	20	2.5
MWRP-060X25.0X2.5	60	55	25	2.5
MWRP-060X30.0X2.5	60	55	30	2.5
MWRP-060X8.0X3.0	60	54	8	3
MWRP-060X15.0X3.0	60	54	15	3
MWRP-060X20.0X3.0	60	54	20	3
MWRP-060X25.0X3.0	60	54	25	3
MWRP-061X25.0X2.0	61	57	25	2
MWRP-061X9.7X2.5	61	56	9.7	2.5
MWRP-061X10.0X2.5	61	56	10	2.5
MWRP-061X15.0X2.5	61	56	15	2.5
MWRP-062X25.0X3.0	62	56	25	3
MWRP-063X4.0X2.0	63	59	4	2
MWRP-063X8.0X2.0	63	59	8	2
MWRP-063X10.0X2.0	63	59	10	2
MWRP-063X8.0X2.5	63	58	8	2.5
MWRP-063X9.5X2.5	63	58	9.5	2.5
MWRP-063X9.7X2.5	63	58	9.7	2.5
MWRP-063X10.0X2.5	63	58	10	2.5
MWRP-063X15.0X2.5	63	58	15	2.5
MWRP-063X20.0X2.5	63	58	20	2.5
MWRP-063X25.0X2.5	63	58	25	2.5
MWRP-063X15.0X3.0	63	57	15	3
MWRP-063X16.0X3.0	63	57	16	3
MWRP-064X15.0X2.0	64	60	15	2
MWRP-065X6.3X2.5	65	60	6.3	2.5
MWRP-065X9.5X2.5	65	60	9.5	2.5
MWRP-065X10.0X2.5	65	60	10	2.5
MWRP-065X15.0X2.5	65	60	15	2.5
MWRP-065X20.0X2.5	65	60	20	2.5
MWRP-065X25.0X2.5	65	60	25	2.5
MWRP-065X30.0X2.5	65	60	30	2.5
MWRP-065X32.0X2.5	65	60	32	2.5
MWRP-065X10.0X3.0	65	59	10	3
MWRP-065X15.0X3.0	65	59	15	3
MWRP-065X16.0X3.0	65	59	16	3

MWRP - Tight Tolerance Metric Guide Ring - C1000

A product of MFP Seals.

MFPSEALS

www.mfpseals.com

MWRP

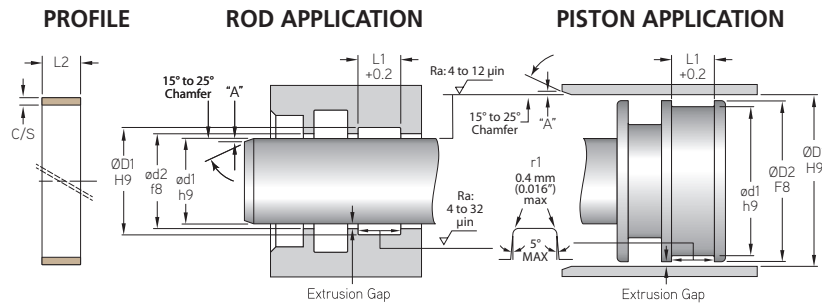

METRIC WEAR RINGS

MFP PART NUMBER	ROD OR PISTON APPLICATION			
	ØD1	ød1	L1	C/S
TOLERANCE	H9	h9	+0.2	
MWRP-065X20.0X3.0	65	59	20	3
MWRP-065X12.0X4.0	65	57	12	4
MWRP-065X10.0X5.0	65	55	10	5
MWRP-066X20.0X2.5	66	61	20	2.5
MWRP-066X10.0X3.0	66	60	10	3
MWRP-066X50.0X3.0	66	60	50	3
MWRP-068X15.0X2.5	68	63	15	2.5
MWRP-069X35.0X2.0	69	65	35	2
MWRP-069X10.0X2.5	69	64	10	2.5
MWRP-069X20.0X2.5	69	64	20	2.5
MWRP-069X30.0X3.0	69	63	30	3
MWRP-069X31.5X3.0	69	63	31.5	3
MWRP-070X10.0X2.0	70	66	10	2
MWRP-070X5.6X2.5	70	65	5.6	2.5
MWRP-070X9.5X2.5	70	65	9.5	2.5
MWRP-070X9.7X2.5	70	65	9.7	2.5
MWRP-070X10.0X2.5	70	65	10	2.5
MWRP-070X15.0X2.5	70	65	15	2.5
MWRP-070X20.0X2.5	70	65	20	2.5
MWRP-070X25.0X2.5	70	65	25	2.5
MWRP-070X12.0X3.0	70	64	12	3
MWRP-070X12.4X3.0	70	64	12.4	3
MWRP-070X14.0X3.0	70	64	14	3
MWRP-070X14.5X3.0	70	64	14.5	3
MWRP-070X15.0X3.0	70	64	15	3
MWRP-070X19.5X3.0	70	64	19.5	3
MWRP-070X20.0X3.0	70	64	20	3
MWRP-070X15.0X5.0	70	60	15	5
MWRP-071X10.0X2.5	71	66	10	2.5
MWRP-071X20.0X2.5	71	66	20	2.5
MWRP-075X9.5X2.5	75	70	9.5	2.5
MWRP-075X9.7X2.5	75	70	9.7	2.5
MWRP-075X10.0X2.5	75	70	10	2.5
MWRP-075X15.0X2.5	75	70	15	2.5
MWRP-075X20.0X2.5	75	70	20	2.5
MWRP-075X25.0X2.5	75	70	25	2.5
MWRP-075X30.0X2.5	75	70	30	2.5

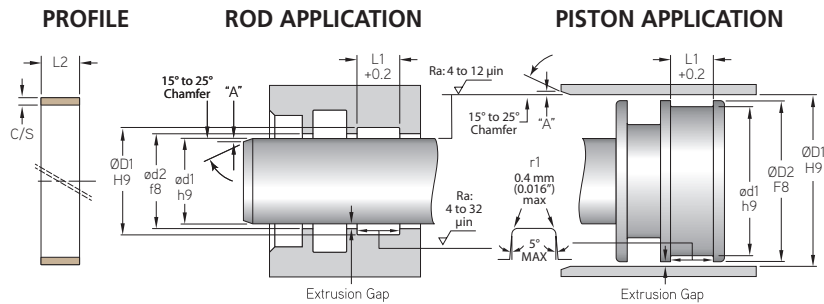

MWRP

MFP PART NUMBER	ROD OR PISTON APPLICATION			
	ØD1	ød1	L1	C/S
TOLERANCE	H9	h9	+0.2	
MWRP-075X40.0X2.5	75	70	40	2.5
MWRP-075X50.0X2.5	75	70	50	2.5
MWRP-075X12.5X3.0	75	69	12.5	3
MWRP-075X15.0X3.0	75	69	15	3
MWRP-075X20.0X3.0	75	69	20	3
MWRP-075X25.0X3.0	75	69	25	3
MWRP-075X11.8X4.0	75	67	11.8	4
MWRP-075X15.0X5.5	75	64	15	5.5
MWRP-076X20.0X2.5	76	71	20	2.5
MWRP-076X10.0X3.0	76	70	10	3
MWRP-076X20.0X3.0	76	70	20	3
MWRP-080X5.0X2.0	80	76	5	2
MWRP-080X8.0X2.0	80	76	8	2
MWRP-080X10.0X2.0	80	76	10	2
MWRP-080X15.0X2.0	80	76	15	2
MWRP-080X30.0X2.0	80	76	30	2
MWRP-080X9.5X2.5	80	75	9.5	2.5
MWRP-080X10.0X2.5	80	75	10	2.5
MWRP-080X15.0X2.5	80	75	15	2.5
MWRP-080X20.0X2.5	80	75	20	2.5
MWRP-080X25.0X2.5	80	75	25	2.5
MWRP-080X6.0X3.0	80	74	6	3
MWRP-080X10.0X3.0	80	74	10	3
MWRP-080X12.0X3.0	80	74	12	3
MWRP-080X15.0X3.0	80	74	15	3
MWRP-080X20.0X3.0	80	74	20	3
MWRP-080X25.0X3.0	80	74	25	3
MWRP-080X10.0X3.1	80	73.8	10	3.1
MWRP-080X10.0X3.5	80	73	10	3.5
MWRP-081X25.0X3.0	81	75	25	3
MWRP-081X37.5X3.0	81	75	37.5	3
MWRP-082X12.0X5.0	82	72	12	5
MWRP-083X6.0X4.0	83	75	6	4
MWRP-085X9.5X2.5	85	80	9.5	2.5
MWRP-085X9.7X2.5	85	80	9.7	2.5
MWRP-085X15.0X2.5	85	80	15	2.5
MWRP-085X20.0X2.5	85	80	20	2.5

METRIC WEAR RINGS

MWRP - Tight Tolerance Metric Guide Ring - C1000

A product of MFP Seals.

MFPSEALS
www.mfpseals.com

MWRP

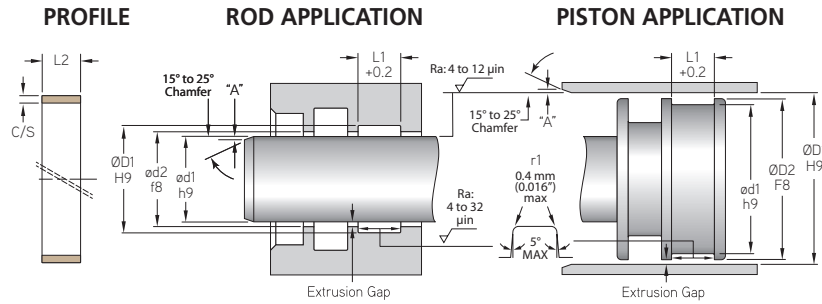

METRIC WEAR RINGS

MFP PART NUMBER	ROD OR PISTON APPLICATION			
	$\varnothing D1$	$\varnothing d1$	L1	C/S
	TOLERANCE			
	H9	h9	+0.2	
MWRP-085X25.0X2.5	85	80	25	2.5
MWRP-085X35.0X2.5	85	80	35	2.5
MWRP-085X10.0X3.0	85	79	10	3
MWRP-085X12.5X3.0	85	79	12.5	3
MWRP-085X15.0X3.0	85	79	15	3
MWRP-085X20.0X3.0	85	79	20	3
MWRP-085X25.0X3.0	85	79	25	3
MWRP-085X10.0X5.0	85	75	10	5
MWRP-086X25.0X3.0	86	80	25	3
MWRP-086X40.0X3.0	86	80	40	3
MWRP-089X10.0X3.5	89	82	10	3.5
MWRP-090X20.0X2.0	90	86	20	2
MWRP-090X6.0X2.5	90	85	6	2.5
MWRP-090X9.5X2.5	90	85	9.5	2.5
MWRP-090X9.7X2.5	90	85	9.7	2.5
MWRP-090X10.0X2.5	90	85	10	2.5
MWRP-090X14.7X2.5	90	85	14.7	2.5
MWRP-090X15.0X2.5	90	85	15	2.5
MWRP-090X20.0X2.5	90	85	20	2.5
MWRP-090X25.0X2.5	90	85	25	2.5
MWRP-090X35.0X2.5	90	85	35	2.5
MWRP-090X40.0X2.5	90	85	40	2.5
MWRP-090X10.0X3.0	90	84	10	3
MWRP-090X12.2X3.0	90	84	12.2	3
MWRP-090X12.5X3.0	90	84	12.5	3
MWRP-090X15.0X3.0	90	84	15	3
MWRP-090X20.0X3.0	90	84	20	3
MWRP-090X25.0X3.0	90	84	25	3
MWRP-090X30.0X3.0	90	84	30	3
MWRP-090X35.0X3.0	90	84	35	3
MWRP-090X15.0X3.2	90	83.7	15	3.2
MWRP-090X5.6X4.0	90	82	5.6	4
MWRP-090X15.0X4.0	90	82	15	4
MWRP-090X12.5X4.5	90	81	12.5	4.5
MWRP-093X12.0X4.5	93	84	12	4.5
MWRP-095X6.0X2.5	95	90	6	2.5
MWRP-095X7.9X2.5	95	90	7.9	2.5

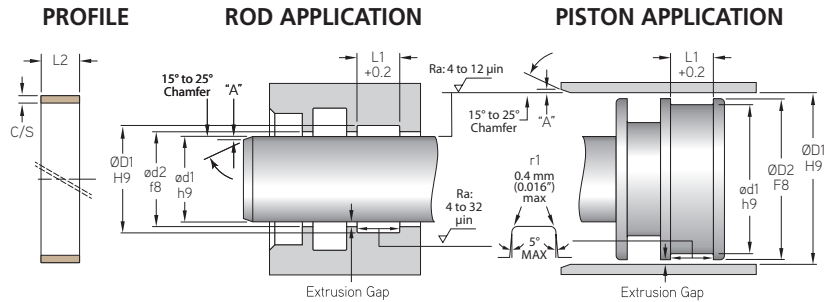

MWRP

MFP PART NUMBER	ROD OR PISTON APPLICATION			
	ØD1	ød1	L1	C/S
TOLERANCE	H9	h9	+0.2	
MWRP-095X9.5X2.5	95	90	9.5	2.5
MWRP-095X10.0X2.5	95	90	10	2.5
MWRP-095X12.5X2.5	95	90	12.5	2.5
MWRP-095X15.0X2.5	95	90	15	2.5
MWRP-095X25.0X2.5	95	90	25	2.5
MWRP-095X50.0X2.5	95	90	50	2.5
MWRP-095X12.5X3.0	95	89	12.5	3
MWRP-095X15.0X3.0	95	89	15	3
MWRP-095X20.0X3.0	95	89	20	3
MWRP-095X25.0X3.0	95	89	25	3
MWRP-095X6.0X4.0	95	87	6	4
MWRP-095X15.0X4.0	95	87	15	4
MWRP-095X12.0X4.5	95	86	12	4.5
MWRP-095X12.3X4.5	95	86	12.3	4.5
MWRP-095X12.5X4.5	95	86	12.5	4.5
MWRP-096X29.0X3.0	96	90	29	3
MWRP-100X5.0X2.0	100	96	5	2
MWRP-100X8.0X2.0	100	96	8	2
MWRP-100X9.7X2.0	100	96	9.7	2
MWRP-100X10.0X2.0	100	96	10	2
MWRP-100X15.0X2.0	100	96	15	2
MWRP-100X5.6X2.5	100	95	5.6	2.5
MWRP-100X6.0X2.5	100	95	6	2.5
MWRP-100X7.9X2.5	100	95	7.9	2.5
MWRP-100X8.0X2.5	100	95	8	2.5
MWRP-100X9.5X2.5	100	95	9.5	2.5
MWRP-100X9.8X2.5	100	95	9.8	2.5
MWRP-100X12.5X2.5	100	95	12.5	2.5
MWRP-100X15.0X2.5	100	95	15	2.5
MWRP-100X20.0X2.5	100	95	20	2.5
MWRP-100X25.0X2.5	100	95	25	2.5
MWRP-100X30.0X2.5	100	95	30	2.5
MWRP-100X10.0X3.0	100	94	10	3
MWRP-100X12.5X3.0	100	94	12.5	3
MWRP-100X14.0X3.0	100	94	14	3
MWRP-100X15.0X3.0	100	94	15	3
MWRP-100X20.0X3.0	100	94	20	3

METRIC WEAR RINGS

MWRP - Tight Tolerance Metric Guide Ring - C1000

A product of MFP Seals.

MFPSEALS
www.mfpseals.com

MWRP

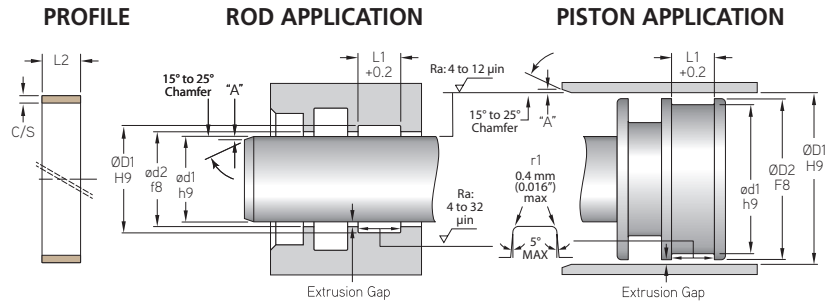

MFP PART NUMBER	ROD OR PISTON APPLICATION			
	ØD1	ød1	L1	C/S
TOLERANCE	H9	h9	+0.2	
MWRP-100X25.0X3.0	100	94	25	3
MWRP-100X30.0X3.0	100	94	30	3
MWRP-100X15.0X3.2	100	93.6	15	3.2
MWRP-100X12.0X3.5	100	93	12	3.5
MWRP-100X10.0X4.0	100	92	10	4
MWRP-100X15.0X4.0	100	92	15	4
MWRP-100X30.0X4.0	100	92	30	4
MWRP-100X10.0X4.5	100	91	10	4.5
MWRP-100X12.1X4.5	100	91	12.1	4.5
MWRP-100X12.5X4.5	100	91	12.5	4.5
MWRP-102X8.0X3.0	102	96	8	3
MWRP-103X12.0X4.5	103	94	12	4.5
MWRP-105X20.0X2.0	105	101	20	2
MWRP-105X6.0X2.5	105	100	6	2.5
MWRP-105X6.1X2.5	105	100	6.1	2.5
MWRP-105X7.9X2.5	105	100	7.9	2.5
MWRP-105X8.0X2.5	105	100	8	2.5
MWRP-105X9.5X2.5	105	100	9.5	2.5
MWRP-105X10.0X2.5	105	100	10	2.5
MWRP-105X15.0X2.5	105	100	15	2.5
MWRP-105X20.0X2.5	105	100	20	2.5
MWRP-105X25.0X2.5	105	100	25	2.5
MWRP-105X35.0X2.5	105	100	35	2.5
MWRP-105X10.0X3.0	105	99	10	3
MWRP-105X12.3X3.0	105	99	12.3	3
MWRP-105X12.5X3.0	105	99	12.5	3
MWRP-105X15.0X3.0	105	99	15	3
MWRP-150X20.0X3.0	105	99	20	3
MWRP-105X25.0X3.0	105	99	25	3
MWRP-105X30.0X3.0	105	99	30	3
MWRP-105X12.5X4.5	105	96	12.5	4.5
MWRP-106X15.0X3.0	106	100	15	3
MWRP-106X20.0X3.0	106	100	20	3
MWRP-106X25.0X3.0	106	100	25	3
MWRP-106X25.0X3.5	106	99	25	3.5
MWRP-108X15.0X3.0	108	102	15	3
MWRP-110X15.0X2.0	110	106	15	2

METRIC WEAR RINGS

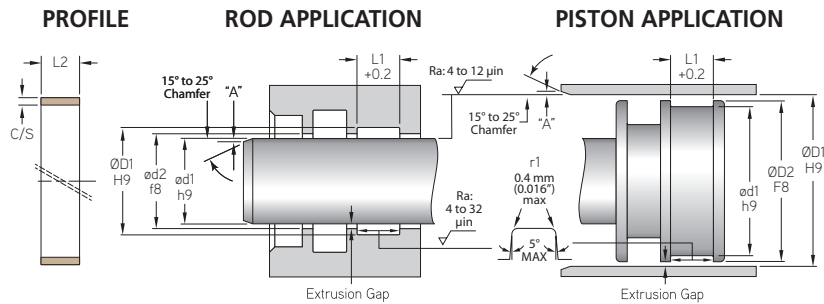

MWRP

MFP PART NUMBER	ROD OR PISTON APPLICATION			
	ØD1	ød1	L1	C/S
TOLERANCE	H9	h9	+0.2	
MWRP-110X6.0X2.5	110	105	6	2.5
MWRP-110X7.9X2.5	110	105	7.9	2.5
MWRP-110X8.0X2.5	110	105	8	2.5
MWRP-110X9.5X2.5	110	105	9.5	2.5
MWRP-110X10.0X2.5	110	105	10	2.5
MWRP-110X15.0X2.5	110	105	15	2.5
MWRP-110X20.0X2.5	110	105	20	2.5
MWRP-110X25.0X2.5	110	105	25	2.5
MWRP-110X30.0X2.5	110	105	30	2.5
MWRP-110X12.0X3.0	110	104	12	3
MWRP-110X12.3X3.0	110	104	12.3	3
MWRP-110X13.0X3.0	110	104	13	3
MWRP-110X14.0X3.0	110	104	14	3
MWRP-110X15.0X3.0	110	104	15	3
MWRP-110X20.0X3.0	110	104	20	3
MWRP-110X25.0X3.0	110	104	25	3
MWRP-110X30.0X3.0	110	104	30	3
MWRP-110X40.0X3.0	110	104	40	3
MWRP-110X35.0X3.5	110	103	35	3.5
MWRP-110X15.0X4.0	110	102	15	4
MWRP-110X10.0X4.5	110	101	10	4.5
MWRP-110X12.1X4.5	110	101	12.1	4.5
MWRP-110X12.5X4.5	110	101	12.5	4.5
MWRP-110X15.0X4.5	110	101	15	4.5
MWRP-112X10.0X3.0	112	106	10	3
MWRP-112X15.0X3.0	112	106	15	3
MWRP-112X20.0X3.0	112	106	20	3
MWRP-112X30.0X3.0	112	106	30	3
MWRP-115X6.0X2.5	115	110	6	2.5
MWRP-115X7.9X2.5	115	110	7.9	2.5
MWRP-115X8.0X2.5	115	110	8	2.5
MWRP-115X9.5X2.5	115	110	9.5	2.5
MWRP-115X10.0X2.5	115	110	10	2.5
MWRP-115X15.0X2.5	115	110	15	2.5
MWRP-115X20.0X2.5	115	110	20	2.5
MWRP-115X25.0X2.5	115	110	25	2.5
MWRP-115X30.0X2.5	115	110	30	2.5

METRIC WEAR RINGS

MWRP - Tight Tolerance Metric Guide Ring - C1000

A product of MFP Seals.

MFPSEALS
www.mfpseals.com

MWRP

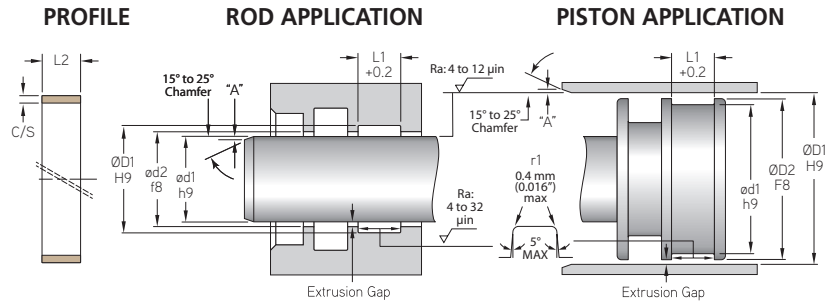

METRIC WEAR RINGS

MFP PART NUMBER	ROD OR PISTON APPLICATION			
	ØD1	ød1	L1	C/S
TOLERANCE	H9	h9	+0.2	
MWRP-115X35.0X2.5	115	110	35	2.5
MWRP-115X15.0X3.0	115	109	15	3
MWRP-115X30.0X3.0	115	109	30	3
MWRP-115X8.0X4.0	115	107	8	4
MWRP-115X15.0X4.0	115	107	15	4
MWRP-115X15.0X4.5	115	106	15	4.5
MWRP-115X15.0X5.0	115	105	15	5
MWRP-115X20.0X5.0	115	105	20	5
MWRP-116X30.0X3.0	116	110	30	3
MWRP-118X30.0X4.0	118	110	30	4
MWRP-118X15.0X5.0	118	108	15	5
MWRP-120X7.9X2.5	120	115	7.9	2.5
MWRP-120X8.0X2.5	120	115	8	2.5
MWRP-120X9.5X2.5	120	115	9.5	2.5
MWRP-120X9.7X2.5	120	115	9.7	2.5
MWRP-120X10.0X2.5	120	115	10	2.5
MWRP-120X14.6X2.5	120	115	14.6	2.5
MWRP-120X15.0X2.5	120	115	15	2.5
MWRP-120X20.0X2.5	120	115	20	2.5
MWRP-120X25.0X2.5	120	115	25	2.5
MWRP-120X10.0X3.0	120	114	10	3
MWRP-120X12.0X3.0	120	114	12	3
MWRP-120X15.0X3.0	120	114	15	3
MWRP-120X20.0X3.0	120	114	20	3
MWRP-120X25.0X3.0	120	114	25	3
MWRP-120X30.0X3.0	120	114	30	3
MWRP-120X35.0X3.0	120	114	35	3
MWRP-120X14.8X3.5	120	113	14.8	3.5
MWRP-120C30.0X3.5	120	113	30	3.5
MWRP-120X5.9X4.0	120	112	5.9	4
MWRP-120X8.0X4.0	120	112	8	4
MWRP-120X9.5X4.0	120	112	9.5	4
MWRP-120X15.0X4.0	120	112	15	4
MWRP-120X15.0X4.5	120	111	15	4.5
MWRP-120X16.0X5.0	120	110	16	5
MWRP-122X15.0X2.5	122	117	15	2.5
MWRP-123X20.0X1.5	123	120	20	1.5

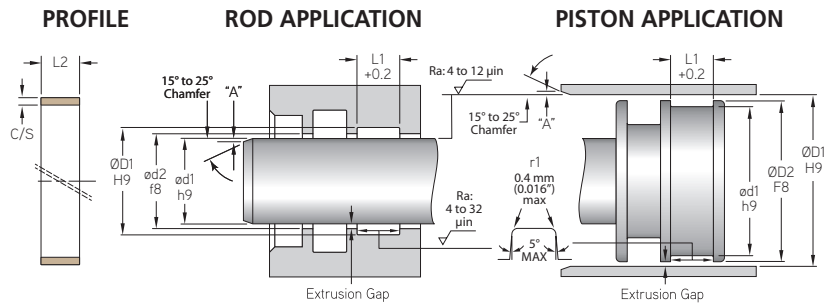

MFP PART NUMBER	ROD OR PISTON APPLICATION			
	ØD1	ød1	L1	C/S
TOLERANCE	H9	h9	+0.2	
MWRP-124X15.0X5.0	124	114	15	5
MWRP-125X10.0X2.0	125	121	10	2
MWRP-125X7.9X2.5	125	120	7.9	2.5
MWRP-125X8.0X2.5	125	120	8	2.5
MWRP-125X9.0X2.5	125	120	9	2.5
MWRP-125X9.5X2.5	125	120	9.5	2.5
MWRP-125X10.0X2.5	125	120	10	2.5
MWRP-125X12.0X2.5	125	120	12	2.5
MWRP-125X15.0X2.5	125	120	15	2.5
MWRP-125X20.0X2.5	125	120	20	2.5
MWRP-125X25.0X2.5	125	120	25	2.5
MWRP-125X30.0X2.5	125	120	30	2.5
MWRP-125X40.0X2.5	125	120	40	2.5
MWRP-125X50.0X2.5	125	120	50	2.5
MWRP-125X8.0X3.0	125	119	8	3
MWRP-125X10.0X3.0	125	119	10	3
MWRP-125X15.0X3.0	125	119	15	3
MWRP-125X20.0X3.0	125	119	20	3
MWRP-125X25.0X3.0	125	119	25	3
MWRP-125X30.0X3.0	125	119	30	3
MWRP-125X10.0X3.5	125	118	10	3.5
MWRP-125X15.0X3.5	125	118	15	3.5
MWRP-125X18.4X3.5	125	118	18.4	3.5
MWRP-125X30.0X3.5	125	118	30	3.5
MWRP-125X50.0X3.5	125	118	50	3.5
MWRP-125X8.0X4.0	125	117	8	4
MWRP-125X15.0X5.5	125	114	15	5.5
MWRP-126X10.0X3.0	126	120	10	3
MWRP-126X30.0X3.0	126	120	30	3
MWRP-127X30.0X3.5	127	120	30	3.5
MWRP-129X30.0X5.0	129	119	30	5
MWRP-130X7.9X2.5	130	125	7.9	2.5
MWRP-130X8.0X2.5	130	125	8	2.5
MWRP-130X9.5X2.5	130	125	9.5	2.5
MWRP-130X9.7X2.5	130	125	9.7	2.5
MWRP-130X10.0X2.5	130	125	10	2.5
MWRP-130X15.0X2.5	130	125	15	2.5

MWRP - Tight Tolerance Metric Guide Ring - C1000

A product of MFP Seals.

MFPSEALS
www.mfpseals.com

MWRP

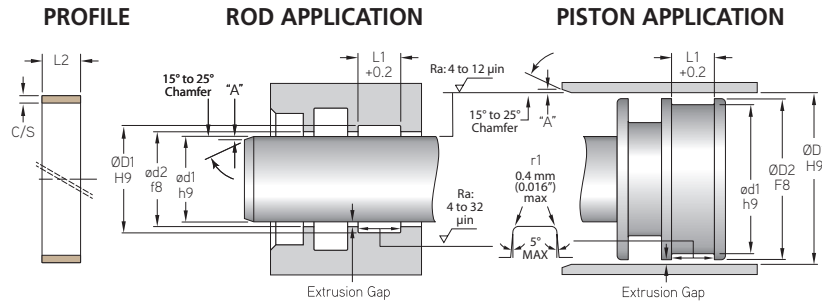

METRIC WEAR RINGS

MFP PART NUMBER	ROD OR PISTON APPLICATION			
	ØD1	ød1	L1	C/S
TOLERANCE	H9	h9	+0.2	
MWRP-130X20.0X2.5	130	125	20	2.5
MWRP-130X25.0X2.5	130	125	25	2.5
MWRP-130X30.0X3.0	130	124	30	3
MWRP-130X10.0X3.5	130	123	10	3.5
MWRP-130X15.0X3.5	130	123	15	3.5
MWRP-130X20.0X3.5	130	123	20	3.5
MWRP-130X25.0X3.5	130	123	25	3.5
MWRP-130X30.0X3.5	130	123	30	3.5
MWRP-130X35.0X3.5	130	123	35	3.5
MWRP-130X40.0X3.5	130	123	40	3.5
MWRP-130X7.9X4.0	130	122	7.9	4
MWRP-130X8.0X4.0	130	122	8	4
MWRP-130X15.0X5.0	130	120	15	5
MWRP-130X16.0X5.0	130	120	16	5
MWRP-131X22.0X2.0	131	127	22	2
MWRP-131X25.0X3.0	131	125	25	3
MWRP-132X35.0X3.5	132	125	35	3.5
MWRP-135X7.0X2.5	135	130	7	2.5
MWRP-135X7.9X2.5	135	130	7.9	2.5
MWRP-135X8.0X2.5	135	130	8	2.5
MWRP-135X9.5X2.5	135	130	9.5	2.5
MWRP-135X15.0X2.5	135	130	15	2.5
MWRP-135X8.0X3.0	135	129	8	3
MWRP-135X14.0X3.0	135	129	14	3
MWRP-135X20.0X3.0	135	129	20	3
MWRP-135X25.0X3.0	135	129	25	3
MWRP-135X30.0X3.0	135	129	30	3
MWRP-135X35.0X3.0	135	129	35	3
MWRP-135X9.7X3.5	135	128	9.7	3.5
MWRP-135X10.0X3.5	135	128	10	3.5
MWRP-135X15.0X3.5	135	128	15	3.5
MWRP-135X25.0X3.5	135	128	25	3.5
MWRP-135X35.0X3.5	135	128	35	3.5
MWRP-135X50.0X3.5	135	128	50	3.5
MWRP-135X8.0X4.0	135	127	8	4
MWRP-135X9.7X4.0	135	127	9.7	4
MWRP-135X9.8X4.0	135	127	9.8	4

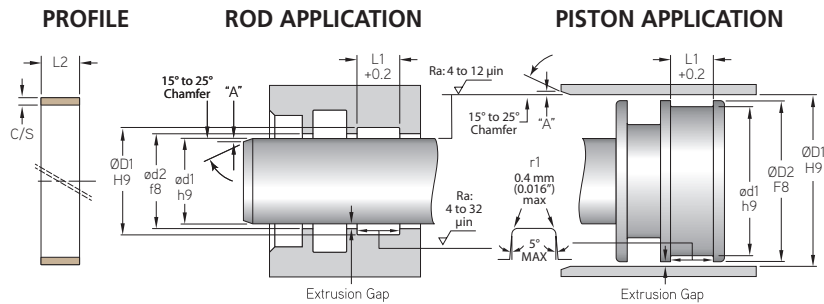

MFP PART NUMBER	ROD OR PISTON APPLICATION			
	ØD1	ød1	L1	C/S
TOLERANCE	H9	h9	+0.2	
MWRP-135X15.0X4.0	135	127	15	4
MWRP-135X15.0X5.0	135	125	15	5
MWRP-136X10.0X3.0	136	130	10	3
MWRP-137X30.0X3.5	137	130	30	3.5
MWRP-137X17.0X5.0	137	127	17	5
MWRP-138X20.0X3.0	138	132	20	3
MWRP-140X7.9X2.5	140	135	7.9	2.5
MWRP-140X8.0X2.5	140	135	8	2.5
MWRP-140X9.5X2.5	140	135	9.5	2.5
MWRP-140X9.7X2.5	140	135	9.7	2.5
MWRP-140X10.0X2.5	140	135	10	2.5
MWRP-140X15.0X2.5	140	135	15	2.5
MWRP-140X20.0X2.5	140	135	20	2.5
MWRP-140X25.0X2.5	140	135	25	2.5
MWRP-140X30.0X2.5	140	135	30	2.5
MWRP-140X35.0X2.5	140	135	35	2.5
MWRP-140X50.0X2.5	140	135	50	2.5
MWRP-140X25.0X3.0	140	134	25	3
MWRP-140X30.0X3.0	140	134	30	3
MWRP-140X40.0X3.0	140	134	40	3
MWRP-140X50.0X3.0	140	134	50	3
MWRP-140X10.0X3.5	140	133	10	3.5
MWRP-140X15.0X3.5	140	133	15	3.5
MWRP-140X17.5X3.5	140	133	17.5	3.5
MWRP-140X20.0X3.5	140	133	20	3.5
MWRP-140X25.0X3.5	140	133	25	3.5
MWRP-140X30.0X3.5	140	133	30	3.5
MWRP-140X34.5X3.5	140	133	34.5	3.5
MWRP-140X35.0X3.5	140	133	35	3.5
MWRP-140X40.0X3.5	140	133	40	3.5
MWRP-140X45.0X3.5	140	133	45	3.5
MWRP-140X50.0X3.5	140	133	50	3.5
MWRP-140X8.0X4.0	140	132	8	4
MWRP-140X30.0X5.0	140	130	30	5
MWRP-140X17.0X6.0	140	128	17	6
MWRP-140X17.5X6.0	140	128	17.5	6
MWRP-140X20.0X6.0	140	128	20	6

MWRP

METRIC WEAR RINGS

MWRP - Tight Tolerance Metric Guide Ring - C1000

A product of MFP Seals.

MFPSEALS
www.mfpseals.com

MWRP

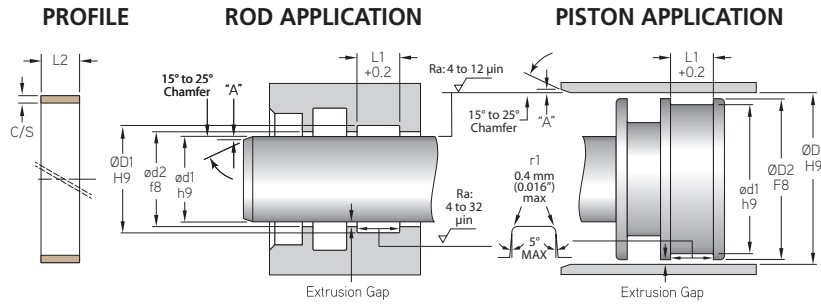

METRIC WEAR RINGS

MFP PART NUMBER	ROD OR PISTON APPLICATION			
	ØD1	ød1	L1	C/S
TOLERANCE	H9	h9	+0.2	
MWRP-140X15.0X11.5	140	117	15	11.5
MWRP-142X15.0X3.5	142	135	15	3.5
MWRP-145X7.9X2.5	145	140	7.9	2.5
MWRP-145X8.0X2.5	145	140	8	2.5
MWRP-145X9.5X2.5	145	140	9.5	2.5
MWRP-145X10.0X2.5	145	140	10	2.5
MWRP-145X15.0X2.5	145	140	15	2.5
MWRP-145X19.8X2.5	145	140	19.8	2.5
MWRP-145X20.0X2.5	145	140	20	2.5
MWRP-145X25.0X2.5	145	140	25	2.5
MWRP-145X50.0X2.5	145	140	50	2.5
MWRP-145X9.7X3.5	145	138	9.7	3.5
MWRP-145X10.0X3.5	145	138	10	3.5
MWRP-145X15.0X3.5	145	138	15	3.5
MWRP-145X20.0X3.5	145	138	20	3.5
MWRP-145X25.0X3.5	145	138	25	3.5
MWRP-145X30.0X3.5	145	138	30	3.5
MWRP-145X35.0X3.5	145	138	35	3.5
MWRP-145X50.0X3.5	145	138	50	3.5
MWRP-145X17.5X6.0	145	133	17.5	6
MWRP-145X40.0X7.5	145	130	40	7.5
MWRP-147X30.0X3.5	147	140	30	3.5
MWRP-147X40.0X3.5	147	140	40	3.5
MWRP-150X7.9X2.5	150	145	7.9	2.5
MWRP-150X8.0X2.5	150	145	8	2.5
MWRP-150X9.5X2.5	150	145	9.5	2.5
MWRP-150X9.7X2.5	150	145	9.7	2.5
MWRP-150X10.0X2.5	150	145	10	2.5
MWRP-150X15.0X2.5	150	145	15	2.5
MWRP-150X20.0X2.5	150	145	20	2.5
MWRP-150X25.0X2.5	150	145	25	2.5
MWRP-150X35.0X2.5	150	145	35	2.5
MWRP-150X40.0X2.5	150	145	40	2.5
MWRP-150X50.0X2.5	150	145	50	2.5
MWRP-150X20.0X3.0	150	144	20	3
MWRP-150X35.0X3.0	150	144	35	3
MWRP-150X40.0X3.0	150	144	40	3

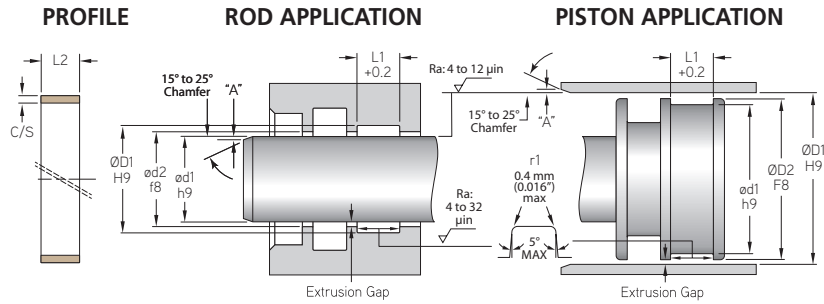

MWRP

MFP PART NUMBER	ROD OR PISTON APPLICATION			
	ØD1	ød1	L1	C/S
TOLERANCE	H9	h9	+0.2	
MWRP-150X50.0X3.0	150	144	50	3
MWRP-150X10.0X3.5	150	143	10	3.5
MWRP-150X15.0X3.5	150	143	15	3.5
MWRP-150X17.5X3.5	150	143	17.5	3.5
MWRP-150X20.0X3.5	150	143	20	3.5
MWRP-150X25.0X3.5	150	143	25	3.5
MWRP-150X30.0X3.5	150	143	30	3.5
MWRP-150X35.0X3.5	150	143	35	3.5
MWRP-150X40.0X3.5	150	143	40	3.5
MWRP-150X45.0X3.5	150	143	45	3.5
MWRP-150X50.0X3.5	150	143	50	3.5
MWRP-150X8.0X4.0	150	142	8	4
MWRP-150X15.0X4.0	150	142	15	4
MWRP-150X17.0X4.0	150	142	17	4
MWRP-150X20.0X4.0	150	142	20	4
MWRP-150X25.0X4.0	150	142	25	4
MWRP-150X9.5X5.0	150	140	9.5	5
MWRP-150X12.0X6.0	150	138	12	6
MWRP-150X17.0X6.0	150	138	17	6
MWRP-150X17.5X6.0	150	138	17.5	6
MWRP-151X50.0X3.0	151	145	50	3
MWRP-152X15.0X2.5	152	147	15	2.5
MWRP-155X7.9X2.5	155	150	7.9	2.5
MWRP-155X8.0X2.5	155	150	8	2.5
MWRP-155X9.5X2.5	155	150	9.5	2.5
MWRP-155X10.0X2.5	155	150	10	2.5
MWRP-155X15.0X2.5	155	150	15	2.5
MWRP-155X20.0X2.5	155	150	20	2.5
MWRP-155X25.0X2.5	155	150	25	2.5
MWRP-155X35.0X3.5	155	148	35	3.5
MWRP-156X35.0X3.0	156	150	35	3
MWRP-157X25.0X2.5	157	152	25	2.5
MWRP-157X40.0X3.5	157	150	40	3.5
MWRP-160X19.5X2.0	160	156	19.5	2
MWRP-160X7.9X2.5	160	155	7.9	2.5
MWRP-160X8.0X2.5	160	155	8	2.5
MWRP-160X9.5X2.5	160	155	9.5	2.5

METRIC WEAR RINGS

MWRP - Tight Tolerance Metric Guide Ring - C1000

A product of MFP Seals.

MFPSEALS
www.mfpseals.com

MWRP

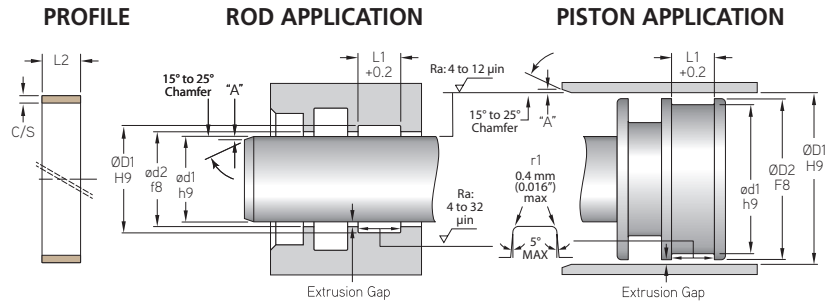

METRIC WEAR RINGS

MFP PART NUMBER	ROD OR PISTON APPLICATION			
	ØD1	ød1	L1	C/S
TOLERANCE	H9	h9	+0.2	
MWRP-160X9.7X2.5	160	155	9.7	2.5
MWRP-160X10.0X2.5	160	155	10	2.5
MWRP-160X15.0X2.5	160	155	15	2.5
MWRP-160X20.0X2.5	160	155	20	2.5
MWRP-160X24.5X2.5	160	155	24.5	2.5
MWRP-160X25.0X2.5	160	155	25	2.5
MWRP-160X50.0X2.5	160	155	50	2.5
MWRP-160X20.0X3.0	160	154	20	3
MWRP-160X10.0X3.5	160	153	10	3.5
MWRP-160X15.0X3.5	160	153	15	3.5
MWRP-160X20.0X3.5	160	153	20	3.5
MWRP-160X25.0X3.5	160	153	25	3.5
MWRP-160X30.0X3.5	160	153	30	3.5
MWRP-160X35.0X3.5	160	153	35	3.5
MWRP-160X40.0X3.5	160	153	40	3.5
MWRP-160X45.0X3.5	160	153	45	3.5
MWRP-160X35.0X4.0	160	152	35	4
MWRP-160X23.0X5.0	160	150	23	5
MWRP-160X20.0X6.0	160	148	20	6
MWRP-160X20.0X6.0	160	148	20	6
MWRP-165X7.9X2.5	165	160	7.9	2.5
MWRP-165X9.5X2.5	165	160	9.5	2.5
MWRP-165X10.0X2.5	165	160	10	2.5
MWRP-165X15.0X2.5	165	160	15	2.5
MWRP-165X20.0X2.5	165	160	20	2.5
MWRP-165X25.0X2.5	165	160	25	2.5
MWRP-165X30.0X2.5	165	160	30	2.5
MWRP-165X35.0X2.5	165	160	35	2.5
MWRP-165X40.0X2.5	165	160	40	2.5
MWRP-165X30.0X3.0	165	159	30	3
MWRP-165X15.0X3.5	165	158	15	3.5
MWRP-165X10.0X4.0	165	157	10	4
MWRP-165X15.0X4.0	165	157	15	4
MWRP-165X20.0X4.0	165	157	20	4
MWRP-165X25.0X4.0	165	157	25	4
MWRP-165X30.0X4.0	165	157	30	4
MWRP-165X35.0X4.0	165	157	35	4

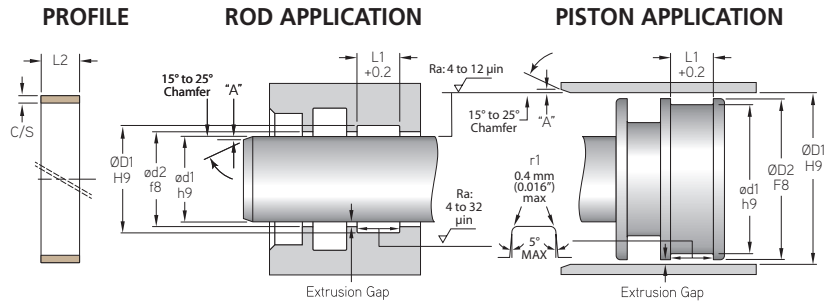

MFP PART NUMBER	ROD OR PISTON APPLICATION			
	ØD1	ød1	L1	C/S
TOLERANCE	H9	h9	+0.2	
MWRP-165X45.0X4.0	165	157	45	4
MWRP-165X50.0X4.0	165	157	50	4
MWRP-165X19.5X6.0	165	153	19.5	6
MWRP-170X7.9X2.5	170	165	7.9	2.5
MWRP-170X8.0X2.5	170	165	8	2.5
MWRP-170X9.5X2.5	170	165	9.5	2.5
MWRP-170X9.7X2.5	170	165	9.7	2.5
MWRP-170X10.0X2.5	170	165	10	2.5
MWRP-170X15.0X2.5	170	165	15	2.5
MWRP-170X20.0X2.5	170	165	20	2.5
MWRP-170X25.0X2.5	170	165	25	2.5
MWRP-170X30.0X2.5	170	165	30	2.5
MWRP-170X35.0X2.5	170	165	35	2.5
MWRP-170X50.0X2.5	170	165	50	2.5
MWRP-170X9.5X3.0	170	164	9.5	3
MWRP-170X9.6X3.0	170	164	9.6	3
MWRP-170X20.0X3.0	170	164	20	3
MWRP-170X25.0X3.0	170	164	25	3
MWRP-170X35.0X3.0	170	164	35	3
MWRP-170X50.0X3.0	170	164	50	3
MWRP-170X14.8X3.5	170	163	14.8	3.5
MWRP-170X40.0X3.5	170	163	40	3.5
MWRP-170X45.0X3.5	170	163	45	3.5
MWRP-170X4.5X4.0	170	162	4.5	4
MWRP-170X9.6X4.0	170	162	9.6	4
MWRP-170X10.0X4.0	170	162	10	4
MWRP-170X15.0X4.0	170	162	15	4
MWRP-170X20.0X4.0	170	162	20	4
MWRP-170X25.0X4.0	170	162	25	4
MWRP-170X25.0X4.0	170	162	25	4
MWRP-170X30.0X4.0	170	162	30	4
MWRP-170X35.0X4.0	170	162	35	4
MWRP-170X40.0X4.0	170	162	40	4
MWRP-170X45.0X4.0	170	162	45	4
MWRP-170X50.0X4.0	170	162	50	4
MWRP-170X20.0X6.0	170	158	20	6
MWRP-175X9.5X2.5	175	170	9.5	2.5

MWRP

METRIC WEAR RINGS

MWRP - Tight Tolerance Metric Guide Ring - C1000

A product of MFP Seals.

MFPSEALS
www.mfpseals.com

MWRP

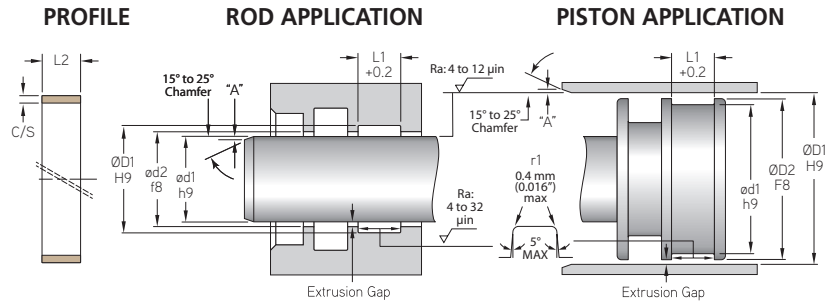

METRIC WEAR RINGS

MFP PART NUMBER	ROD OR PISTON APPLICATION			
	ØD1	ød1	L1	C/S
TOLERANCE	H9	h9	+0.2	
MWRP-175X19.8X2.5	175	170	19.8	2.5
MWRP-175X20.0X2.5	175	170	20	2.5
MWRP-175X25.0X2.5	175	170	25	2.5
MWRP-175X50.0X3.0	175	169	50	3
MWRP-175X40.0X4.0	175	167	40	4
MWRP-180X7.9X2.5	180	175	7.9	2.5
MWRP-180X8.0X2.5	180	175	8	2.5
MWRP-180X9.5X2.5	180	175	9.5	2.5
MWRP-180X10.0X2.5	180	175	10	2.5
MWRP-180X12.0X2.5	180	175	12	2.5
MWRP-180X12.5X2.5	180	175	12.5	2.5
MWRP-180X15.0X2.5	180	175	15	2.5
MWRP-180X20.0X2.5	180	175	20	2.5
MWRP-180X25.0X2.5	180	175	25	2.5
MWRP-180X30.0X2.5	180	175	30	2.5
MWRP-180X35.0X2.5	180	175	35	2.5
MWRP-180X40.0X2.5	180	175	40	2.5
MWRP-180X45.0X2.5	180	175	45	2.5
MWRP-180X50.0X2.5	180	175	50	2.5
MWRP-180X14.8X3.0	180	174	14.8	3
MWRP-180X20.0X3.0	180	174	20	3
MWRP-180X35.0X3.0	180	174	35	3
MWRP-180X50.0X3.0	180	174	50	3
MWRP-180X14.8X3.5	180	173	14.8	3.5
MWRP-180X20.0X3.5	180	173	20	3.5
MWRP-180X50.0X3.5	180	173	50	3.5
MWRP-180X9.5X4.0	180	172	9.5	4
MWRP-180X9.6X4.0	180	172	9.6	4
MWRP-180X10.0X4.0	180	172	10	4
MWRP-180X12.0X4.0	180	172	12	4
MWRP-180X15.0X4.0	180	172	15	4
MWRP-180X20.0X4.0	180	172	20	4
MWRP-180X22.0X4.0	180	172	22	4
MWRP-180X22.5X4.0	180	172	22.5	4
MWRP-180X25.0X4.0	180	172	25	4
MWRP-180X30.0X4.0	180	172	30	4
MWRP-180X35.0X4.0	180	172	35	4

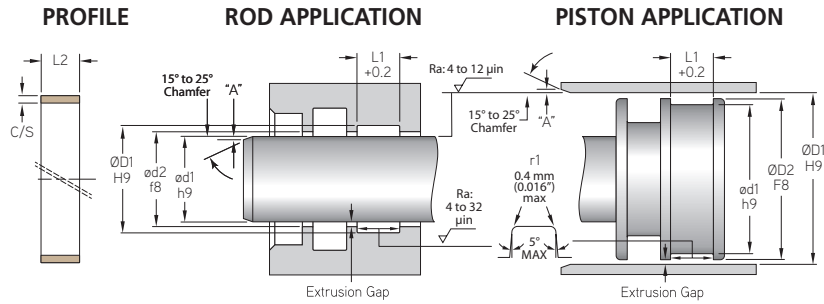

MWRP

MFP PART NUMBER	ROD OR PISTON APPLICATION			
	ØD1	ød1	L1	C/S
TOLERANCE	H9	h9	+0.2	
MWRP-180X40.0X4.0	180	172	40	4
MWRP-180X45.0X4.0	180	172	45	4
MWRP-180X50.0X4.0	180	172	50	4
MWRP-180X55.0X4.0	180	172	55	4
MWRP-180X8.0X5.0	180	170	8	5
MWRP-180X19.0X5.0	180	170	19	5
MWRP-180X25.0X5.0	180	170	25	5
MWRP-180X22.5X6.0	180	168	22.5	6
MWRP-185X15.0X2.5	185	180	15	2.5
MWRP-185X25.0X2.5	185	180	25	2.5
MWRP-185X50.0X2.5	185	180	50	2.5
MWRP-185X15.0X4.0	185	177	15	4
MWRP-185X22.5X6.0	185	173	22.5	6
MWRP-190X8.0X2.5	190	185	8	2.5
MWRP-190X9.5X2.5	190	185	9.5	2.5
MWRP-190X10.0X2.5	190	185	10	2.5
MWRP-190X15.0X2.5	190	185	15	2.5
MWRP-190X25.0X2.5	190	185	25	2.5
MWRP-190X30.0X2.5	190	185	30	2.5
MWRP-190X14.8X3.0	190	184	14.8	3
MWRP-190X50.0X3.0	190	184	50	3
MWRP-190X30.0X3.5	190	183	30	3.5
MWRP-190X35.0X3.5	190	183	35	3.5
MWRP-190X9.6X4.0	190	182	9.6	4
MWRP-190X10.0X4.0	190	182	10	4
MWRP-190X15.0X4.0	190	182	15	4
MWRP-190X20.0X4.0	190	182	20	4
MWRP-190X22.0X4.0	190	182	22	4
MWRP-190X22.5X4.0	190	182	22.5	4
MWRP-190X25.0X4.0	190	182	25	4
MWRP-190X30.0X4.0	190	182	30	4
MWRP-190X35.0X4.0	190	182	35	4
MWRP-190X45.0X4.0	190	182	45	4
MWRP-190X50.0X4.0	190	182	50	4
MWRP-190X19.0X5.0	190	180	19	5
MWRP-190X38.0X6.5	190	177	38	6.5
MWRP-195X10.0X2.5	195	190	10	2.5

METRIC WEAR RINGS

MWRP - Tight Tolerance Metric Guide Ring - C1000

A product of MFP Seals.

MFPSEALS
www.mfpseals.com

MWRP

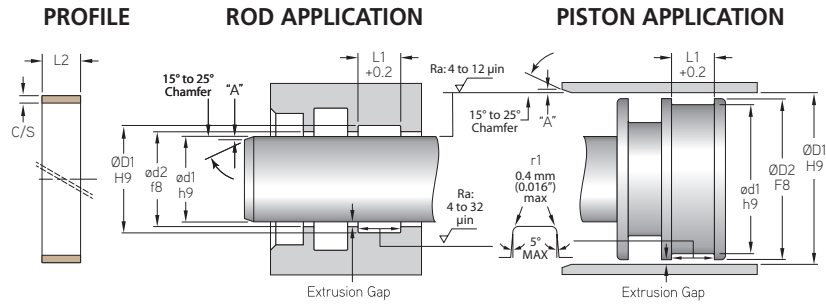

METRIC WEAR RINGS

MFP PART NUMBER	ROD OR PISTON APPLICATION			
	ØD1	ød1	L1	C/S
TOLERANCE	H9	h9	+0.2	
MWRP-195X15.0X2.5	195	190	15	2.5
MWRP-195X20.0X2.5	195	190	20	2.5
MWRP-195X25.0X2.5	195	190	25	2.5
MWRP-195X30.0X2.5	195	190	30	2.5
MWRP-200X9.7X2.5	200	195	9.7	2.5
MWRP-200X14.8X2.5	200	195	14.8	2.5
MWRP-200X14.8X3.0	200	194	14.8	3
MWRP-200X19.5X3.0	200	194	19.5	3
MWRP-200X19.8X3.0	200	194	19.8	3
MWRP-200X9.6X4.0	200	192	9.6	4
MWRP-200X10.0X4.0	200	192	10	4
MWRP-200X15.0X4.0	200	192	15	4
MWRP-200X20.0X4.0	200	192	20	4
MWRP-200X22.0X4.0	200	192	22	4
MWRP-200X22.5X4.0	200	192	22.5	4
MWRP-200X25.0X4.0	200	192	25	4
MWRP-200X28.0X4.0	200	192	28	4
MWRP-200X30.0X4.0	200	192	30	4
MWRP-200X40.0X4.0	200	192	40	4
MWRP-200X44.8X4.0	200	192	44.8	4
MWRP-200X45.0X4.0	200	192	45	4
MWRP-200X50.0X4.0	200	192	50	4
MWRP-200X90.0X4.0	200	192	90	4
MWRP-200X22.5X6.0	200	188	22.5	6
MWRP-200X90.0X6.0	200	188	90	6
MWRP-205X120.0X2.5	205	200	120	2.5
MWRP-210X9.7X2.5	210	205	9.7	2.5
MWRP-210X15.0X2.5	210	205	15	2.5
MWRP-215X19.8X3.0	215	209	19.8	3
MWRP-215X9.6X4.0	215	207	9.6	4
MWRP-220X120.0X6.0	220	208	120	6
MWRP-225X25.0X4.0	225	217	25	4
MWRP-225X50.0X4.0	225	217	50	4
MWRP-225X25.0X6.0	225	213	25	6
MWRP-225X25.0X6.5	225	212	25	6.5
MWRP-230X24.8X2.5	230	225	24.8	2.5
MWRP-230X24.8X3.0	230	224	24.8	3

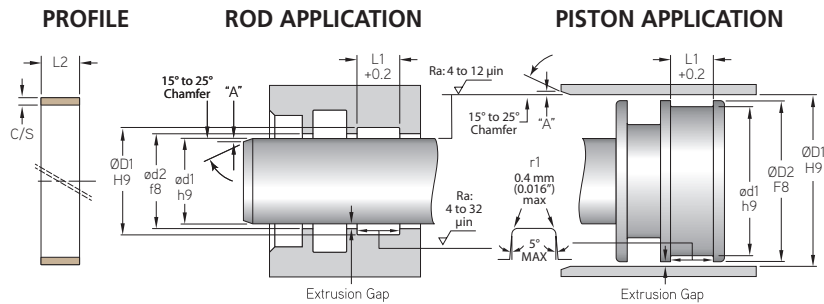

MFP PART NUMBER	ROD OR PISTON APPLICATION			
	ØD1	ød1	L1	C/S
TOLERANCE	H9	h9	+0.2	
MWRP-230X14.8X4.0	230	222	14.8	4
MWRP-230X40.0X4.5	230	221	40	4.5
MWRP-240X25.0X2.5	240	235	25	2.5
MWRP-240X24.8X3.0	240	234	24.8	3
MWRP-240X24.8X3.5	240	233	24.8	3.5
MWRP-240X28.4X3.5	240	233	28.4	3.5
MWRP-240X15.0X4.0	240	232	15	4
MWRP-240X24.8X6.3	240	227.4	24.8	6.3
MWRP-250X14.8X2.5	250	245	14.8	2.5
MWRP-250X55.0X4.0	250	242	55	4
MWRP-250X27.0X6.0	250	238	27	6
MWRP-250X129.5X6.0	250	238	129.5	6
MWRP-255X38.0X6.5	255	242	38	6.5
MWRP-260X9.6X2.5	260	255	9.6	2.5
MWRP-260X14.8X3.0	260	254	14.8	3
MWRP-260X29.8X3.0	260	254	29.8	3
MWRP-260X14.8X4.0	260	252	14.8	4
MWRP-260X27.5X6.0	260	248	27.5	6
MWRP-280X25.0X2.5	280	275	25	2.5
MWRP-280X29.5X3.0	280	274	29.5	3
MWRP-280X30.0X4.0	280	272	30	4
MWRP-280X30.0X6.0	280	268	30	6
MWRP-285X25.0X2.5	285	280	25	2.5
MWRP-300X60.0X4.0	300	292	60	4
MWRP-300X29.6X6.0	300	288	29.6	6
MWRP-310X34.2X3.0	310	304	34.2	3
MWRP-310X19.8X3.5	310	303	19.8	3.5
MWRP-320X14.0X3.5	320	313	14	3.5
MWRP-320X70.0X4.0	320	312	70	4

MWRP

METRIC WEAR RINGS