



MPSP - Metric (2 P.C.) Piston Seal

A product of MFP Seals.

MFPSEALS
www.mfpseals.com

MPSP

MPSP - METRIC (2PC) PISTON SEAL

MFP Seals MPSP piston seal is designed for use in medium duty hydraulic applications. This two piece design is composed of an N6001 O-Ring expander with a Urethane cap produced from our U2151 compound the seal offers extremely low compression set and excellent extrusion resistance.



The standard compound for this seal is U2151, with an N6001 expander.

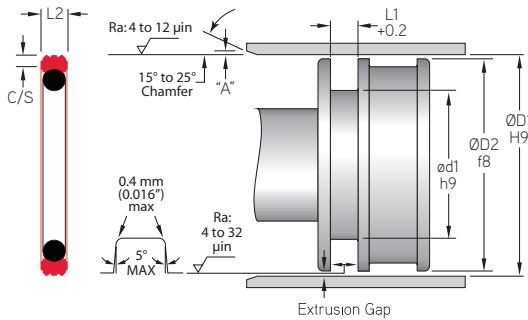

MFP PART NUMBER

MPSP-015X007.5X3.2U2151

SEAL TYPE ØD1 ød1 L1 COMPOUND

Pressure: 350 bar (5,000 psi) Max. Velocity: 0.1 m/s (0.3 ft./s)

METRIC PISTON ASSEMBLIES

MFP PART NUMBER	ROD APPLICATION			
	ØD1	ØD2	ød1	L1
TOLERANCE	H9	f8	h9	+0.2
MPSP-015X007.5X3.2	15	15	7.5	3.2
MPSP-016X008.5X3.2	16	16	8.5	3.2
MPSP-020X012.5X3.2	20	20	12.5	3.2
MPSP-022X014.5X3.2	22	22	14.5	3.2
MPSP-025X014.0X4.2	25	25	14	4.2
MPSP-025X017.5X3.2	25	25	17.5	3.2
MPSP-028X020.5X3.2	28	28	20.5	3.2
MPSP-030X022.5X3.2	30	30	22.5	3.2
MPSP-032X021.0X4.2	32	32	21	4.2
MPSP-032X024.5X3.2	32	32	24.5	3.2
MPSP-035X027.5X3.2	35	35	27.5	3.2
MPSP-040X024.5X6.3	40	40	24.5	6.3
MPSP-040X032.5X3.2	40	40	32.5	3.2
MPSP-040X029.0X4.2	40	40	29	4.2
MPSP-045X029.5X6.3	45	45	29.5	6.3
MPSP-045X034.0X4.2	45	45	34	4.2
MPSP-048X037.0X4.2	48	48	37	4.2
MPSP-049X038.0X4.2	49	49	38	4.2
MPSP-050X034.5X6.3	50	50	34.5	6.3
MPSP-050X039.0X4.2	50	50	39	4.2
MPSP-052X036.5X6.3	52	52	36.5	6.3
MPSP-054X043.0X4.2	54	54	43	4.2
MPSP-055X039.5X6.3	55	55	39.5	6.3
MPSP-055X044.0X4.2	55	55	44	4.2
MPSP-060X044.5X6.3	60	60	44.5	6.3

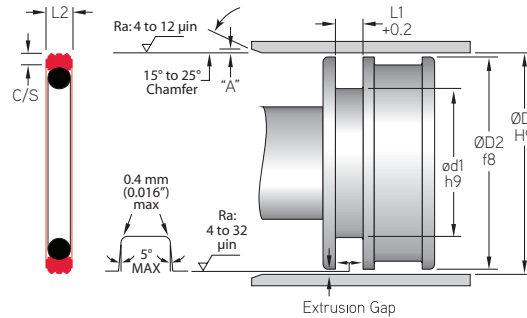

MPSP

MFP PART NUMBER	ROD APPLICATION			
	ØD1	ØD2	ød1	L1
TOLERANCE	H9	f7	h9	+0.2
MPSP-060X049.0X4.2	60	60	49	4.2
MPSP-063X047.5X6.3	63	63	47.5	6.3
MPSP-063X052.0X4.2	63	63	52	4.2
MPSP-065X049.5X6.3	65	65	49.5	6.3
MPSP-065X052.0X6.3	65	65	52	6.3
MPSP-065X054.0X4.2	65	65	54	4.2
MPSP-070X054.5X6.3	70	70	54.5	6.3
MPSP-070X057.0X6.3	70	70	57	6.3
MPSP-070X059.0X4.2	70	70	59	4.2
MPSP-075X059.5X6.3	75	75	59.5	6.3
MPSP-075X064.0X4.2	75	75	64	4.2
MPSP-080X064.5X6.3	80	80	64.5	6.3
MPSP-080X069.0X4.2	80	80	69	4.2
MPSP-085X069.5X6.3	85	85	69.5	6.3
MPSP-090X074.5X6.3	90	90	74.5	6.3
MPSP-100X084.5X6.3	100	100	84.5	6.3
MPSP-105X089.5X6.3	105	105	89.5	6.3
MPSP-110X094.5X6.3	110	110	94.5	6.3
MPSP-115X099.5X6.3	115	115	99.5	6.3
MPSP-120X099.0X8.1	120	120	99	8.1
MPSP-120X104.5X6.3	120	120	104.5	6.3
MPSP-125X104.0X8.1	125	125	104	8.1
MPSP-125X109.5X6.3	125	125	109.5	6.3
MPSP-130X109.0X8.1	130	130	109	8.1
MPSP-130X114.5X6.3	130	130	114.5	6.3
MPSP-135X114.0X8.1	135	135	114	8.1
MPSP-140X119.0X8.1	140	140	119	8.1
MPSP-140X124.5X6.3	140	140	124.5	6.3
MPSP-150X129.0X8.1	150	150	129	8.1
MPSP-160X139.0X8.1	160	160	139	8.1
MPSP-165X144.0X8.1	165	165	144	8.1
MPSP-170X149.0X8.1	170	170	149	8.1
MPSP-180X159.0X8.1	180	180	159	8.1
MPSP-190X169.0X8.1	190	190	169	8.1
MPSP-200X179.0X8.1	200	200	179	8.1
MPSP-210X189.0X8.1	210	210	189	8.1
MPSP-225X204.0X8.1	225	225	204	8.1
MPSP-230X209.0X8.1	230	230	209	8.1

METRIC PISTON ASSEMBLIES