



MPST METRIC (2PC) PISTON SEAL

MFP Seals' MPST piston seal is made for use in light to medium duty hydraulic applications. This two piece design is composed of an O-Ring energizer and a PTFE cap produced from our proprietary T5100 compound.



The standard compound for this seal is T5100 / N6001.

For increased chemical and temperature resistance, other compounds are available (See pages 20-37).

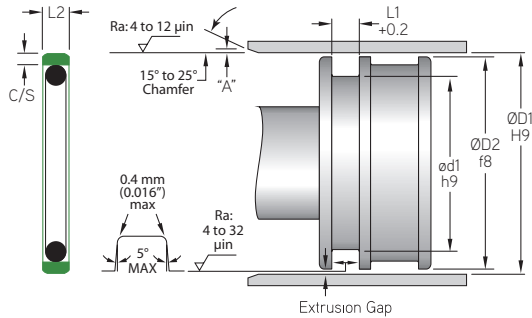

MFP PART NUMBER

MPST-016x011.0x2.2T5100N

SEAL TYPE ØD1 ød1 L1 COMPOUND EXPANDER COMPOUND

Pressure: 400 bar (5,800 psi) Max. Velocity: 3.0 m/s (9 ft./s)

MFP PART NUMBER	PISTON APPLICATION			
	ØD1	ØD2	ød1	L1
TOLERANCE	H9	f8	h9	+0.2
MPST-010X005.0X2.2	10	10	5	2.2
MPST-012X007.0X2.2	12	12	7	2.2
MPST-014X009.0X2.2	14	14	9	2.2
MPST-015X007.5X3.2	15	15	7.5	3.2
MPST-016X011.0X2.2	16	16	11	2.2
MPST-016X008.5X3.2	16	16	8.5	3.2
MPST-018X010.5X3.2	18	18	10.5	3.2
MPST-020X015.0X2.2	20	20	15	2.2
MPST-020X012.5X3.2	20	20	12.5	3.2
MPST-022X014.5X3.2	22	22	14.5	3.2
MPST-025X017.5X3.2	25	25	17.5	3.2
MPST-025X014.0X4.2	25	25	14	4.2
MPST-028X020.5X3.2	28	28	20.5	3.2
MPST-030X022.5X3.2	30	30	22.5	3.2
MPST-032X024.5X3.2	32	32	24.5	3.2
MPST-032X021.0X4.2	32	32	21	4.2
MPST-035X027.5X3.2	35	35	27.5	3.2
MPST-036X028.5X3.2	36	36	28.5	3.2
MPST-040X032.5X3.2	40	40	32.5	3.2
MPST-040X029.0X4.2	40	40	29	4.2
MPST-045X034.0X4.2	45	45	34	4.2
MPST-048X037.0X4.2	48	48	37	4.2
MPST-050X039.0X4.2	50	50	39	4.2
MPST-050X034.5X6.3	50	50	34.5	6.3
MPST-052X041.0X4.2	52	52	41	4.2



MPST - Metric (2 P.C.) Piston Seal

A product of MFP Seals.

MFPSEALS
www.mfpseals.com

MPST

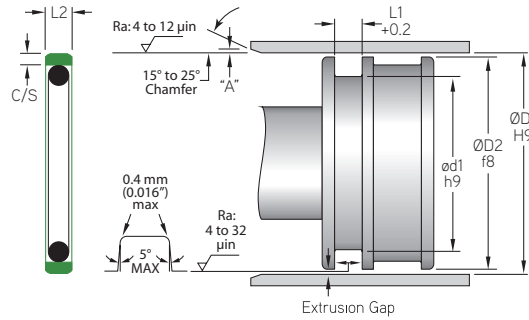

METRIC PISTON ASSEMBLIES

MFP PART NUMBER	PISTON APPLICATION			
	ØD1	ØD2	ød1	L1
TOLERANCE	H9	f8	h9	+0.2
MPST-055X044.0X4.2	55	55	44	4.2
MPST-060X049.0X4.2	60	60	49	4.2
MPST-063X055.5X3.2	63	63	55.5	3.2
MPST-063X052.0X4.2	63	63	52	4.2
MPST-063X047.5X6.3	63	63	47.5	6.3
MPST-065X054.0X4.2	65	65	54	4.2
MPST-070X054.5X6.3	70	70	54.5	6.3
MPST-070X059.0X4.2	70	70	59	4.2
MPST-075X064.0X4.2	75	75	64	4.2
MPST-080X069.0X4.2	80	80	69	4.2
MPST-080X064.5X6.3	80	80	64.5	6.3
MPST-080X059.0X8.1	80	80	59	8.1
MPST-085X064.0X8.1	85	85	64	8.1
MPST-085X069.5X6.3	85	85	69.5	6.3
MPST-090X074.5X6.3	90	90	74.5	6.3
MPST-090X069.0X8.1	90	90	69	8.1
MPST-095X079.5X6.3	95	95	79.5	6.3
MPST-095X074.0X8.1	95	95	74	8.1
MPST-100X089.0X4.2	100	100	89	4.2
MPST-100X084.5X6.3	100	100	84.5	6.3
MPST-100X079.0X8.1	100	100	79	8.1
MPST-105X084.0X8.1	105	105	84	8.1
MPST-105X089.5X6.3	105	105	89.5	6.3
MPST-110X089.0X8.1	110	110	89	8.1
MPST-110X094.5X6.3	110	110	94.5	6.3
MPST-115X094.0X8.1	115	115	94	8.1
MPST-120X099.0X8.1	120	120	99	8.1
MPST-120X104.5X6.3	120	120	104.5	6.3
MPST-125X109.5X6.3	125	125	109.5	6.3
MPST-125X104.0X8.1	125	125	104	8.1
MPST-127X111.5X6.3	127	127	111.5	6.3
MPST-130X109.0X8.1	130	130	109	8.1
MPST-130X114.5X6.3	130	130	114.5	6.3
MPST-135X114.0X8.1	135	135	114	8.1
MPST-140X119.0X8.1	140	140	119	8.1
MPST-150X129.0X8.1	150	150	129	8.1
MPST-160X144.5X6.3	160	160	144.5	6.3
MPST-160X135.5X8.1	160	160	135.5	8.1

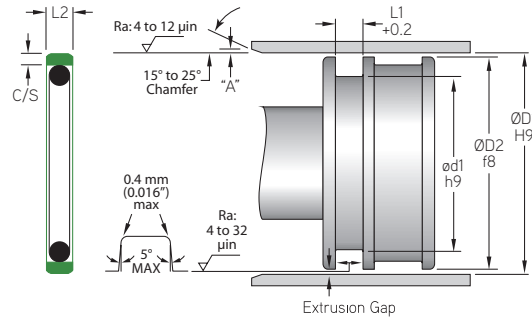

MPST

MFP PART NUMBER	PISTON APPLICATION			
	ØD1	ØD2	ød1	L1
TOLERANCE	H9	f8	h9	+0.2
MPST-160X139.0X8.1	160	160	139	8.1
MPST-170X149.0X8.1	170	170	149	8.1
MPST-180X159.0X8.1	180	180	159	8.1
MPST-190X169.0X8.1	190	190	169	8.1
MPST-200X184.5X6.3	200	200	184.5	6.3
MPST-200X175.5X8.1	200	200	175.5	8.1
MPST-200X179.0X8.1	200	200	179	8.1
MPST-210X189.0X8.1	210	210	189	8.1
MPST-220X199.0X8.1	220	220	199	8.1
MPST-225X204.0X8.1	225	225	204	8.1
MPST-230X209.0X8.1	230	230	209	8.1
MPST-240X219.0X8.1	240	240	219	8.1
MPST-250X229.0X8.1	250	250	229	8.1
MPST-260X239.0X8.1	260	260	239	8.1
MPST-280X259.0X8.1	280	280	259	8.1
MPST-300X279.0X8.1	300	300	279	8.1
MPST-320X295.5X8.1	320	320	295.5	8.1
MPST-350X325.5X8.1	350	350	325.5	8.1
MPST-360X335.5X8.1	360	360	335.5	8.1
MPST-380X355.5X8.1	380	380	355.5	8.1
MPST-400X375.5X8.1	400	400	375.5	8.1
MPST-420X395.5X8.1	420	420	395.5	8.1
MPST-450X425.5X8.1	450	450	425.5	8.1
MPST-480X455.5X8.1	480	480	455.5	8.1
MPST-500X475.5X8.1	500	500	475.5	8.1

METRIC PISTON ASSEMBLIES