



MXP - METRIC X-PAC® LOADED B-LIP SYMMETRICAL U-CUP

Metric X-PAC® U-Cups are a very versatile reciprocating seal design, for use up to 350 bar (5,000 psi). The rubber expander creates a compression style seal while still operating as a pressure actuated U-Cup design. The result is better low-pressure sealing and less startup leakage.

The primary function of the B-Lip X-PAC® is for linear rod applications. However, they can also be used for piston applications when straight lip tooling is not available. MFP Seals' X-PAC® U-Cups feature a knife trimmed sealing lip for increased sealability.

Glands must be a minimum of 110% of the height of seal used. Free space is necessary to allow for the thermal expansion of the seal material and swell due to the effects of the system fluids. Pressure must be able to contact both sealing lips.



The standard compound for this seal is U2145. It is also available in compounds U2150, U2151, U2162, U4150 and H2155, with an N6014 X-Ring expander.

MFP PART NUMBER

MXP-008X016X05.7BU2145

SEAL TYPE ØD1 L2 COMPOUND
ød1 PROFILE STYLE

Pressure: 350 bar (5,000 psi)

Max. Velocity: 0.5 m/s (< 1.6 ft./s)

PROFILE

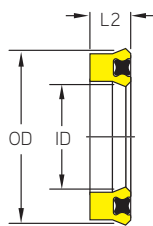

ROD APPLICATION

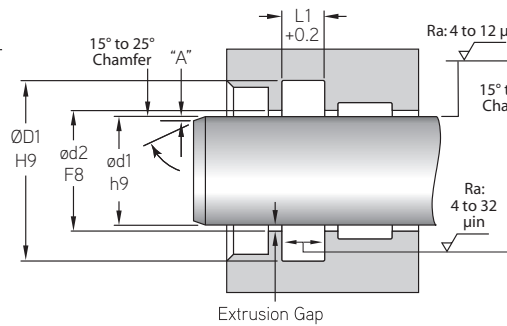

PISTON APPLICATION

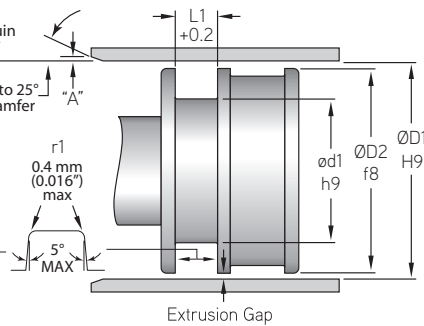

ROD OR PISTON APPLICATION

MFP PART NUMBER	ød1	ød2	ØD1	ØD2	L2	L1
TOLERANCE	h9	F8	H9	f8		+0.2
MXP-008X016X05.7B	8	8	16	16	5.7	6.7
MXP-009X017X05.7B	9	9	17	17	5.7	6.7
MXP-009X019X08.0B	9	9	19	19	8	9
MXP-010X016X06.3B	10	10	16	16	6.3	7.3
MXP-010X018X05.7B	10	10	18	18	5.7	6.7
MXP-010X018X08.0B	10	10	18	18	8	9
MXP-010X020X08.0B	10	10	20	20	8	9
MXP-011.2X019.2X05.0B	11.2	11.2	19.2	19.2	5	6
MXP-012X018X06.0B	12	12	18	18	6	7
MXP-012X019X04.6B	12	12	19	19	4.6	5.6
MXP-012X020X05.0B	12	12	20	20	5	6
MXP-012X020X06.4B	12	12	20	20	6.4	7.4
MXP-012X020X07.3B	12	12	20	20	7.3	8.3



Metric X-PAC® Loaded B-Lip - Symmetrical U-Cup

A product of MFP Seals.

MFPSEALS®

www.mfpseals.com

**METRIC X-PAC®
B-LIP**

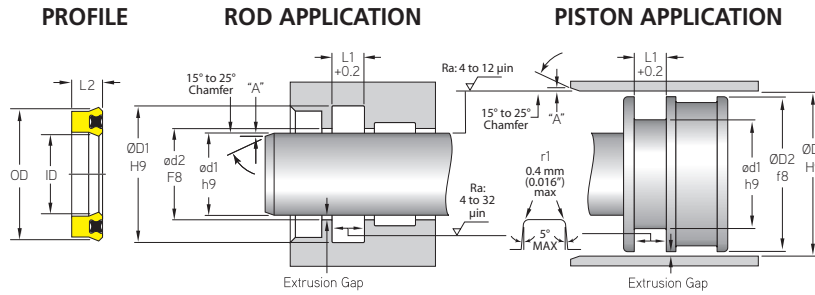

METRIC SYMMETRICAL U-CUPS

MFP PART NUMBER	ROD OR PISTON APPLICATION					
	ØD1	ØD2	ØD1	ØD2	L2	L1
TOLERANCE	h9	F8	H9	f8		+0.2
MXP-012X022X06.0B	12	12	22	22	6	7
MXP-012X022X07.3B	12	12	22	22	7.3	8.3
MXP-012X022X08.0B	12	12	22	22	8	9
MXP-012.5X022.5X08.0B	12.5	12.5	22.5	22.5	8	9
MXP-013X019X04.0B	13	13	19	19	4	5
MXP-014X021X04.6B	14	14	21	21	4.6	5.6
MXP-014X022X05.0B	14	14	22	22	5	6
MXP-014X024X05.5B	14	14	24	24	5.5	6.5
MXP-014X024X08.0B	14	14	24	24	8	9
MXP-015X022X05.0B	15	15	22	22	5	6
MXP-015X025X08.0B	15	15	25	25	8	9
MXP-016X022X04.0B	16	16	22	22	4	5
MXP-016X024X05.0B	16	16	24	24	5	6
MXP-016X024X08.0B	16	16	24	24	8	9
MXP-016X026X08.0B	16	16	26	26	8	9
MXP-017X025X10.0B	17	17	25	25	10	11
MXP-018X025X04.6B	18	18	25	25	4.6	5.6
MXP-018X026X05.0B	18	18	26	26	5	6
MXP-018X026X05.2B	18	18	26	26	5.2	6.2
MXP-018X028X08.0B	18	18	28	28	8	9
MXP-020X026X05.0B	20	20	26	26	5	6
MXP-020X027X06.0B	20	20	27	27	6	7
MXP-020X028X05.0B	20	20	28	28	5	6
MXP-020X028X05.7B	20	20	28	28	5.7	6.7
MXP-020X028X07.2B	20	20	28	28	7.2	8.2
MXP-020X030X06.0B	20	20	30	30	6	7
MXP-020X030X07.2B	20	20	30	30	7.2	8.2
MXP-020X030X08.0B	20	20	30	30	8	9
MXP-020X032X06.0B	20	20	32	32	6	7
MXP-020X032X08.0B	20	20	32	32	8	9
MXP-020X035X10.0B	20	20	35	35	10	11
MXP-020X035X12.0B	20	20	35	35	12	13
MXP-020X040X12.0B	20	20	40	40	12	13
MXP-022X028X05.3B	22	22	28	28	5.3	6.3
MXP-022X029X04.6B	22	22	29	29	4.6	5.6
MXP-022X030X05.0B	22	22	30	30	5	6
MXP-022X030X05.7B	22	22	30	30	5.7	6.7
MXP-022X030X06.0B	22	22	30	30	6	7
MXP-022X030X07.0B	22	22	30	30	7	8

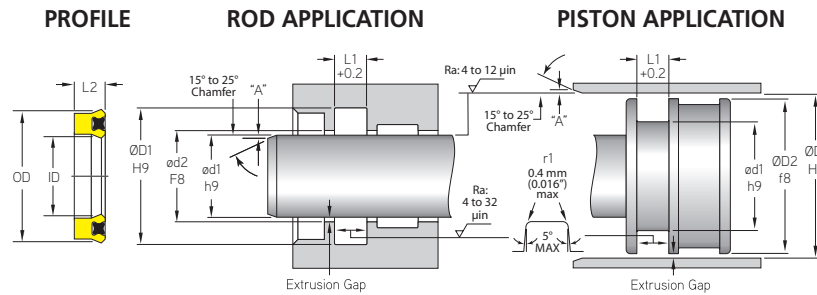

METRIC X-PAC®
B-LIP

MFP PART NUMBER	ROD OR PISTON APPLICATION					
	ØD1	ØD2	ØD1	ØD2	L2	L1
TOLERANCE	h9	F8	H9	f8		+0.2
MXP-022X030X07.2B	22	22	30	30	7.2	8.2
MXP-022X030X08.0B	22	22	30	30	8	9
MXP-022X032X06.0B	22	22	32	32	6	7
MXP-022X032X07.3B	22	22	32	32	7.3	8.3
MXP-022X032.4X08.0B	22	22	32.4	32.4	8	9
MXP-022X035X08.0B	22	22	35	35	8	9
MXP-022X035X10.0B	22	22	35	35	10	11
MXP-022X040X12.0B	22	22	40	40	12	13
MXP-022.4X030X05.0B	22.4	22.4	30	30	5	6
MXP-022.4X032.4X08.0B	22.4	22.4	32.4	32.4	8	9
MXP-23.5X31.5X05.0B	23.5	23.5	31.5	31.5	5	6
MXP-025X033X05.0B	25	25	33	33	5	6
MXP-025X033X05.5B	25	25	33	33	5.5	6.5
MXP-025X033X08.0B	25	25	33	33	8	9
MXP-025X033X10.0B	25	25	33	33	10	11
MXP-025X035X07.3B	25	25	35	35	7.3	8.3
MXP-025X035X08.0B	25	25	35	35	8	9
MXP-025X035X10.0B	25	25	35	35	10	11
MXP-025X038X08.0B	25	25	38	38	8	9
MXP-025X038X10.0B	25	25	38	38	10	11
MXP-025X040X10.0B	25	25	40	40	10	11
MXP-028X035.5X05.0B	28	28	35.5	35.5	5	6
MXP-028X036X05.3B	28	28	36	36	5.3	6.3
MXP-028X036X08.0B	28	28	36	36	8	9
MXP-028X037.5X07.8B	28	28	37.5	37.5	7.8	8.8
MXP-028X038X10.0B	28	28	38	38	10	11
MXP-028X040X10.0B	28	28	40	40	10	11
MXP-028X043X10.2B	28	28	43	43	10.2	11.2
MXP-028X048X12.0B	28	28	48	48	12	13
MXP-030X037X06.0B	30	30	37	37	6	7
MXP-030X038X05.7B	30	30	38	38	5.7	6.7
MXP-030X038X06.3B	30	30	38	38	6.3	7.3
MXP-030X038X08.0B	30	30	38	38	8	9
MXP-030X040X06.0B	30	30	40	40	6	7
MXP-030X040X06.5B	30	30	40	40	6.5	7.5
MXP-030X040X07.0B	30	30	40	40	7	8
MXP-030X040X07.3B	30	30	40	40	7.3	8.3
MXP-030X040X10.0B	30	30	40	40	10	11
MXP-030X042X09.0B	30	30	42	42	9	10

METRIC SYMMETRICAL U-CUPS



Metric X-PAC® Loaded B-Lip - Symmetrical U-Cup

A product of MFP Seals.

MFPSEALS®
www.mfpseals.com

**METRIC X-PAC®
B-LIP**

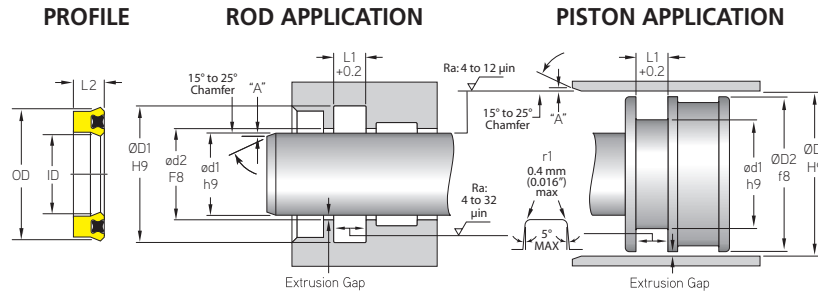

METRIC SYMMETRICAL U-CUPS

MFP PART NUMBER	ROD OR PISTON APPLICATION					
	ØD1	ØD2	ØD1	ØD2	L2	L1
TOLERANCE	h9	F8	H9	f8		+0.2
MXP-030X042X10.0B	30	30	42	42	10	11
MXP-030X045X09.0B	30	30	45	45	9	10
MXP-030X045X09.3B	30	30	45	45	9.3	10.3
MXP-030X045X10.0B	30	30	45	45	10	11
MXP-030X050X10.0B	30	30	50	50	10	11
MXP-031.5X041.5X06.0B	31.5	31.5	41.5	41.5	6	7
MXP-032X040X05.7B	32	32	40	40	5.7	6.7
MXP-032X040X05.7B	32	32	40	40	7.5	8.5
MXP-032X040X08.0B	32	32	40	40	8	9
MXP-032X042X07.3B	32	32	42	42	7.3	8.3
MXP-032X042X10.0B	32	32	42	42	10	11
MXP-032X044X05.0B	32	32	44	44	5	6
MXP-032X044X05.5B	32	32	44	44	5.5	6.5
MXP-032X044X06.3B	32	32	44	44	6.3	7.3
MXP-032X045X10.0B	32	32	45	45	10	11
MXP-032X047X10.0B	32	32	47	47	10	11
MXP-032X048X10.0B	32	32	48	48	10	11
MXP-033X040X08.0B	33	33	40	40	8	9
MXP-033X043X10.0B	33	33	43	43	10	11
MXP-035X042X08.0B	35	35	42	42	8	9
MXP-035X043X06.4B	35	35	43	43	6.4	7.4
MXP-035X043X08.0B	35	35	43	43	8	9
MXP-035X045X06.0B	35	35	45	45	6	7
MXP-035X045X07.3B	35	35	45	45	7.3	8.3
MXP-035X045X08.0B	35	35	45	45	8	9
MXP-035X045X10.0B	35	35	45	45	10	11
MXP-035X050X10.0B	35	35	50	50	10	11
MXP-035X050X11.4B	35	35	50	50	11.4	12.4
MXP-035X051X10.0B	35	35	51	51	10	11
MXP-035X055X10.0B	35	35	55	55	10	11
MXP-035.5X045X06.0B	35.5	35.5	45	45	6	7
MXP-036X043X05.3B	36	36	43	43	5.3	6.3
MXP-036X044X06.0B	36	36	44	44	6	7
MXP-036X044X08.0B	36	36	44	44	8	9
MXP-036X046X07.3B	36	36	46	46	7.3	8.3
MXP-036X046X10.0B	36	36	46	46	10	11
MXP-036X052X10.0B	36	36	52	52	10	11
MXP-037X047X08.0B	37	37	47	47	8	9
MXP-040X048X05.0B	40	40	48	48	5	6

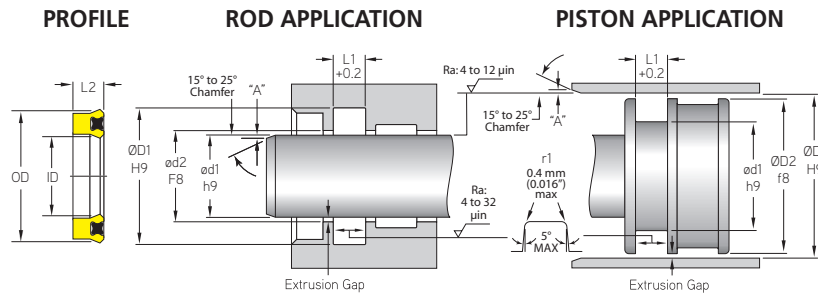

**METRIC X-PAC®
B-LIP**

METRIC SYMMETRICAL U-CUPS

MFP PART NUMBER	ROD OR PISTON APPLICATION					
	ØD1	ØD2	ØD1	ØD2	L2	L1
TOLERANCE	h9	F8	H9	f8		+0.2
MXP-040X048X05.7B	40	40	48	48	5.7	6.7
MXP-040X048X06.0B	40	40	48	48	6	7
MXP-040X048X08.0B	40	40	48	48	8	9
MXP-040X050X06.0B	40	40	50	50	6	7
MXP-040X050X06.5B	40	40	50	50	6.5	7.5
MXP-040X050X07.0B	40	40	50	50	7	8
MXP-040X050X07.3B	40	40	50	50	7.3	8.3
MXP-040X050X08.0B	40	40	50	50	8	9
MXP-040X050X10.0B	40	40	50	50	10	11
MXP-040X053X08.0B	40	40	53	53	8	9
MXP-040X055X09.0B	40	40	55	55	9	10
MXP-040X055X10.0B	40	40	55	55	10	11
MXP-040X056X10.0B	40	40	56	56	10	11
MXP-040X060X12.0B	40	40	60	60	12	13
MXP-041.7X050.7X07.1B	41.7	41.7	50.7	50.7	7.1	8.1
MXP-042X050X06.0B	42	42	50	50	6	7
MXP-042X055X07.0B	42	42	55	55	7	8
MXP-045X053X05.0B	45	45	53	53	5	6
MXP-045X053X08.0B	45	45	53	53	8	9
MXP-045X055X06.0B	45	45	55	55	6	7
MXP-045X055X07.3B	45	45	55	55	7.3	8.3
MXP-045X055X10.0B	45	45	55	55	10	11
MXP-045X056X07.0B	45	45	56	56	7	8
MXP-045X060X09.0B	45	45	60	60	9	10
MXP-045X060X10.0B	45	45	60	60	10	11
MXP-045X060X11.5B	45	45	60	60	11.5	12.5
MXP-045X065X12.0B	45	45	65	65	12	13
MXP-045X070X15.0B	45	45	70	70	15	16
MXP-048X063X10.2B	48	48	63	63	10.2	11.2
MXP-048X068X12.0B	48	48	68	68	12	13
MXP-050X058X08.0B	50	50	58	58	8	9
MXP-050X060X06.0B	50	50	60	60	6	7
MXP-050X060X07.3B	50	50	60	60	7.3	8.3
MXP-050X060X08.0B	50	50	60	60	8	9
MXP-050X060X10.0B	50	50	60	60	10	11
MXP-050X060X12.0B	50	50	60	60	12	13
MXP-050X063X08.0B	50	50	63	63	8	9
MXP-050X063X10.0B	50	50	63	63	10	11
MXP-050X065X09.0B	50	50	65	65	9	10



Metric X-PAC® Loaded B-Lip - Symmetrical U-Cup

A product of MFP Seals.

MFPSEALS®

www.mfpseals.com

**METRIC X-PAC®
B-LIP**

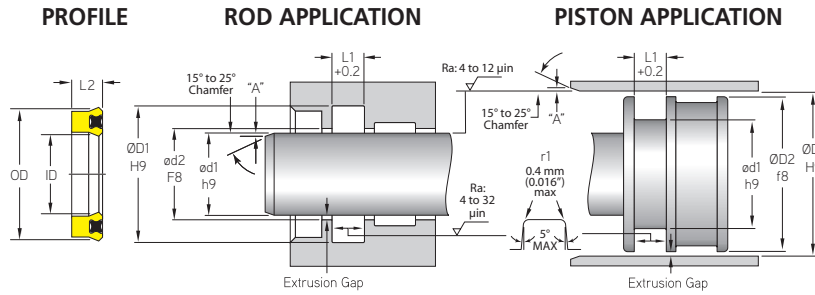

METRIC SYMMETRICAL U-CUPS

MFP PART NUMBER	ROD OR PISTON APPLICATION					
	ØD1	ØD2	ØD1	ØD2	L2	L1
TOLERANCE	h9	F8	H9	f8		+0.2
MXP-050X065X10.0B	50	50	65	65	10	11
MXP-050X065X11.4B	50	50	65	65	11.4	12.4
MXP-050X070X10.0B	50	50	70	70	10	11
MXP-050X070X12.0B	50	50	70	70	12	13
MXP-053X063X06.0B	53	53	63	63	6	7
MXP-053X063X06.5B	53	53	63	63	6.5	7.5
MXP-053X063X07.3B	53	53	63	63	7.3	8.3
MXP-053X063X10.0B	53	53	63	63	10	11
MXP-055X065X06.0B	55	55	65	65	6	7
MXP-055X065X07.3B	55	55	65	65	7.3	8.3
MXP-055X065X10.0B	55	55	65	65	10	11
MXP-055X065X12.0B	55	55	65	65	12	13
MXP-055X068X10.0B	55	55	68	68	10	11
MXP-055X070X09.0B	55	55	70	70	9	10
MXP-055X070X12.0B	55	55	70	70	12	13
MXP-055X075X12.0B	55	55	75	75	12	13
MXP-055X080X15.0B	55	55	80	80	15	16
MXP-056X064X08.0B	56	56	64	64	8	9
MXP-056X066X07.3B	56	56	66	66	6	7
MXP-056X066X10.0B	56	56	66	66	10	11
MXP-056X071X11.4B	56	56	71	71	11.4	12.4
MXP-057X070X09.0B	57	57	70	70	9	10
MXP-060X068X08.0B	60	60	68	68	8	9
MXP-060X070X06.0B	60	60	70	70	6	7
MXP-060X070X07.3B	60	60	70	70	7.3	8.3
MXP-060X070X08.0B	60	60	70	70	8	9
MXP-060X070X09.0B	60	60	70	70	9	10
MXP-060X070X10.0B	60	60	70	70	10	11
MXP-060X070X12.0B	60	60	70	70	12	13
MXP-060X071X07.0B	60	60	71	71	7	8
MXP-060X073X10.0B	60	60	73	73	10	11
MXP-060X075X09.0B	60	60	75	75	9	10
MXP-060X075X10.0B	60	60	75	75	10	11
MXP-060X075X11.0B	60	60	75	75	11	12
MXP-060X080X12.0B	60	60	80	80	12	13
MXP-060X080X14.5B	60	60	80	80	14.5	15.5
MXP-062X072X12.0B	62	62	72	72	12	13
MXP-063X071X08.0B	63	63	71	71	8	9
MXP-063X073X06.0B	63	63	73	73	6	7

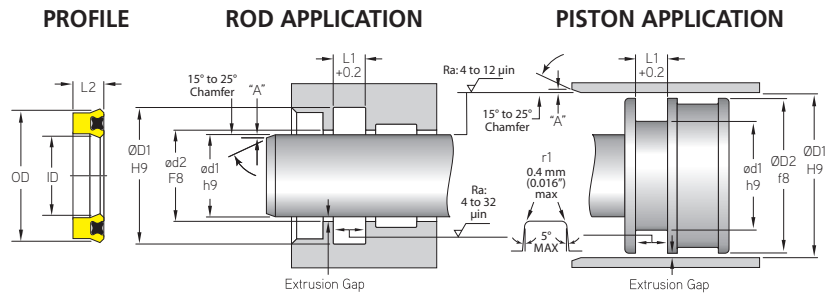

**METRIC X-PAC®
B-LIP**

MFP PART NUMBER	ROD OR PISTON APPLICATION					
	ØD1	ØD2	ØD1	ØD2	L2	L1
TOLERANCE	h9	F8	H9	f8		+0.2
MXP-063X073X12.0B	63	63	73	73	12	13
MXP-063X075X08.7B	63	63	75	75	8.7	9.7
MXP-063X078X10.6B	63	63	78	78	10.6	11.6
MXP-063X078X11.4B	63	63	78	78	11.4	12.4
MXP-063X083X15.0B	63	63	83	83	15	16
MXP-064X080X12.0B	64	64	80	80	12	13
MXP-065X073X08.0B	65	65	73	73	8	9
MXP-065X075X06.0B	65	65	75	75	6	7
MXP-065X075X08.0B	65	65	75	75	8	9
MXP-065X075X10.0B	65	65	75	75	10	11
MXP-065X075X12.0B	65	65	75	75	12	13
MXP-065X078X10.0B	65	65	78	78	10	11
MXP-065X080X09.0B	65	65	80	80	9	10
MXP-065X080X10.0B	65	65	80	80	10	11
MXP-065X080X11.4B	65	65	80	80	11.4	12.4
MXP-065X080X12.0B	65	65	80	80	12	13
MXP-065X085X12.0B	65	65	85	85	12	13
MXP-067X077X06.0B	67	67	77	77	6	7
MXP-070X078X08.0B	70	70	78	78	8	9
MXP-070X080X06.0B	70	70	80	80	6	7
MXP-070X080X10.0B	70	70	80	80	10	11
MXP-070X080X12.0B	70	70	80	80	12	13
MXP-070X083X10.0B	70	70	83	83	10	11
MXP-070X085X09.0B	70	70	85	85	9	10
MXP-070X085X10.0B	70	70	85	85	10	11
MXP-070X085X11.4B	70	70	85	85	11.4	12.4
MXP-070X085X12.0B	70	70	85	85	12	13
MXP-070X090X12.0B	70	70	90	90	12	13
MXP-070X090X15.0B	70	70	90	90	15	16
MXP-071X080X06.0B	71	71	80	80	6	7
MXP-071X080X06.5B	71	71	80	80	6.5	7.5
MXP-072X082X08.0B	72	72	82	82	8	9
MXP-072X087X09.0B	72	72	87	87	9	10
MXP-075X083X06.0B	75	75	83	83	6	7
MXP-075X085X06.0B	75	75	85	85	6	7
MXP-075X085X08.0B	75	75	85	85	8	9
MXP-075X085X10.0B	75	75	85	85	10	11
MXP-075X085X12.0B	75	75	85	85	12	13
MXP-075X090X09.0B	75	75	90	90	9	10

METRIC SYMMETRICAL U-CUPS



Metric X-PAC® Loaded B-Lip - Symmetrical U-Cup

A product of MFP Seals.

MFPSEALS®
www.mfpseals.com

**METRIC X-PAC®
B-LIP**

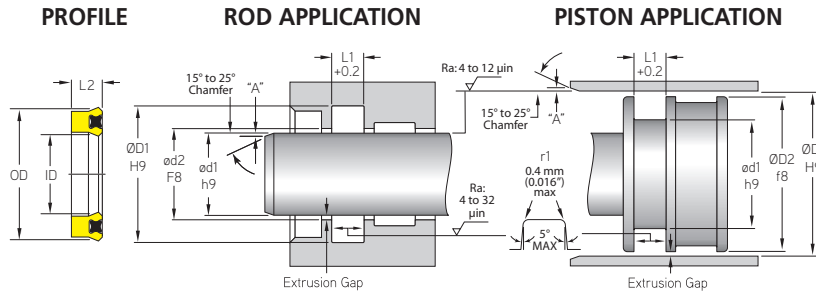

METRIC SYMMETRICAL U-CUPS

MFP PART NUMBER	ROD OR PISTON APPLICATION					
	ØD1	ØD2	ØD1	ØD2	L2	L1
TOLERANCE	h9	F8	H9	f8		+0.2
MXP-075X090X10.0B	75	75	90	90	10	11
MXP-075X090X11.0B	75	75	90	90	11	12
MXP-075X090X11.4B	75	75	90	90	11.4	12.4
MXP-075X095X12.0B	75	75	95	95	12	13
MXP-075X100X15.0B	75	75	100	100	15	16
MXP-078X090X11.0B	78	78	90	90	11	12
MXP-080X088X08.0B	80	80	88	88	8	9
MXP-080X090X06.0B	80	80	90	90	6	7
MXP-080X090X08.0B	80	80	90	90	8	9
MXP-080X090X10.0B	80	80	90	90	10	11
MXP-080X090X12.0B	80	80	90	90	12	13
MXP-080X092X09.5B	80	80	92	92	9.5	10.5
MXP-080X093X10.0B	80	80	93	93	10	11
MXP-080X095X09.0B	80	80	95	95	9	10
MXP-080X095X11.0B	80	80	95	95	11	12
MXP-080X095X11.4B	80	80	95	95	11.4	12.4
MXP-080X100X12.0B	80	80	100	100	12	13
MXP-080X100X14.5B	80	80	100	100	14.5	15.5
MXP-080X100X15.0B	80	80	100	100	15	16
MXP-082X092X10.0B	82	82	92	92	10	11
MXP-084X098X12.0B	84	84	98	98	12	13
MXP-085X100X09.0B	85	85	100	100	9	10
MXP-085X100X10.0B	85	85	100	100	10	11
MXP-085X100X12.0B	85	85	100	100	12	13
MXP-085X105X12.0B	85	85	105	105	12	13
MXP-085X105X14.5B	85	85	105	105	14.5	15.5
MXP-088X102X10.5B	88	88	102	102	10.5	11.5
MXP-090X098X08.0B	90	90	98	98	8	9
MXP-090X100X06.0B	90	90	100	100	6	7
MXP-090X100X07.0B	90	90	100	100	7	8
MXP-090X105X09.0B	90	90	105	105	9	10
MXP-090X105X10.0B	90	90	105	105	10	11
MXP-090X105X11.4B	90	90	105	105	11.4	12.4
MXP-090X105X12.0B	90	90	105	105	12	13
MXP-090X105X10.0B	90	90	105	105	10	11
MXP-090X105X11.4B	90	90	105	105	11.4	12.4
MXP-090X105X12.0B	90	90	105	105	12	13
MXP-090X110X12.0B	90	90	110	110	12	13
MXP-090X110X14.5B	90	90	110	110	14.5	15.5

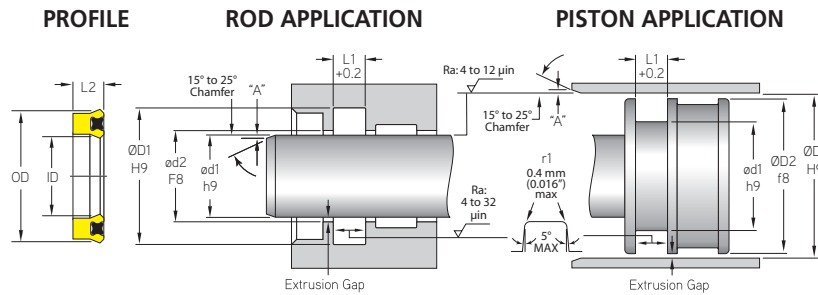

**METRIC X-PAC®
B-LIP**

MFP PART NUMBER	ROD OR PISTON APPLICATION					
	ØD1	ØD2	ØD1	ØD2	L2	L1
TOLERANCE	h9	F8	H9	f8		+0.2
MXP-095X105X06.0B	95	95	105	105	6	7
MXP-095X110X09.0B	95	95	110	110	9	10
MXP-095X110X10.0B	95	95	110	110	10	11
MXP-095X110X11.4B	95	95	110	110	11.4	12.4
MXP-095X110X12.0B	95	95	110	110	12	13
MXP-095X110X09.0B	95	95	110	110	9	10
MXP-095X110X10.0B	95	95	110	110	10	11
MXP-095X110X12.0B	95	95	110	110	12	13
MXP-095X115X12.0B	95	95	115	115	12	13
MXP-097X105X13.0B	97	97	105	105	13	14
MXP-098X110X16.0B	98	98	110	110	16	17
MXP-098X112X10.5B	98	98	112	112	10.5	11.5
MXP-100X050.7X07.1B	100	100	108	108	8	9
MXP-100X115X09.0B	100	100	115	115	9	10
MXP-100X115X10.0B	100	100	115	115	10	11
MXP-100X115X12.0B	100	100	115	115	12	13
MXP-100X115X09.0B	100	100	115	115	9	10
MXP-100X115X10.0B	100	100	115	115	10	11
MXP-100X115X12.0B	100	100	115	115	12	13
MXP-100X120X12.0B	100	100	120	120	12	13
MXP-100X120X14.5B	100	100	120	120	14.5	15.5
MXP-100X125X12.4B	100	100	125	125	12.4	13.4
MXP-100X125X15.0B	100	100	125	125	15	16
MXP-100X125X18.0B	100	100	125	125	18	19
MXP-105X120X09.0B	105	105	120	120	9	10
MXP-105X120X09.0B	105	105	120	120	9	10
MXP-105X125X11.4B	105	105	125	125	11.4	12.4
MXP-105X125X12.0B	105	105	125	125	12	13
MXP-105X125X15.0B	105	105	125	125	15	16
MXP-106X120X08.5B	106	106	120	120	8.5	9.5
MXP-110X125X09.0B	110	110	125	125	9	10
MXP-110X125X09.2B	110	110	125	125	9.2	10.2
MXP-110X125X10.0B	110	110	125	125	10	11
MXP-110X125X11.4B	110	110	125	125	11.4	12.4
MXP-110X125X12.0B	110	110	125	125	12	13
MXP-110X125X09.0B	110	110	125	125	9	10
MXP-110X125X09.2B	110	110	125	125	9.2	10.2
MXP-110X125X10.0B	110	110	125	125	10	11
MXP-110X125X12.0B	110	110	125	125	12	13

METRIC SYMMETRICAL U-CUPS



Metric X-PAC® Loaded B-Lip - Symmetrical U-Cup

A product of MFP Seals.

MFPSEALS®
www.mfpseals.com

**METRIC X-PAC®
B-LIP**

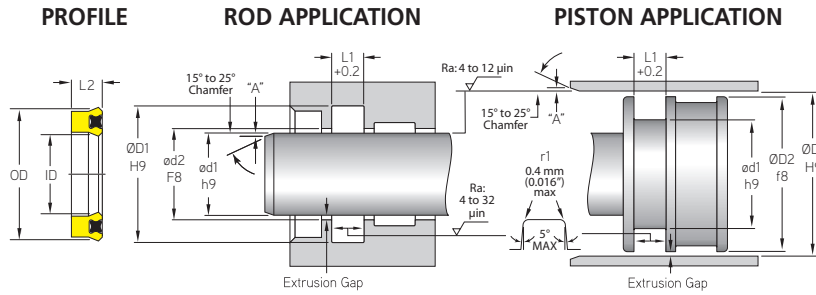

METRIC SYMMETRICAL U-CUPS

MFP PART NUMBER	ROD OR PISTON APPLICATION					
	ød1	ød2	ØD1	ØD2	L2	L1
TOLERANCE	h9	F8	H9	f8		+0.2
MXP-110X130X12.0B	110	110	130	130	12	13
MXP-110X130X14.5B	110	110	130	130	14.5	15.5
MXP-110X130X15.0B	110	110	130	130	15	16
MXP-110X135X18.0B	110	110	135	135	18	19
MXP-112X125X07.0B	112	112	125	125	7	8
MXP-112X125X09.0B	112	112	125	125	9	10
MXP-115X130X08.5B	115	115	130	130	8.5	9.5
MXP-115X130X11.4B	115	115	130	130	11.4	12.4
MXP-115X130X08.5B	115	115	130	130	8.5	9.5
MXP-115X135X12.0B	115	115	135	135	12	13
MXP-115X140X18.0B	115	115	140	140	18	19
MXP-118X133X09.0B	118	118	133	133	9	10
MXP-120X130X15.0B	120	120	130	130	15	16
MXP-120X135X09.0B	120	120	135	135	9	10
MXP-120X135X011.4B	120	120	135	135	11.4	12.4
MXP-120X135X09.0B	120	120	135	135	9	10
MXP-120X135X15.0B	120	120	135	135	15	16
MXP-120X140X10.0B	120	120	140	140	10	11
MXP-120X140X12.0B	120	120	140	140	12	13
MXP-120X140X14.5B	120	120	140	140	14.5	15.5
MXP-120X140X15.0B	120	120	140	140	15	16
MXP-125X135X15.0B	125	125	135	135	15	16
MXP-125X140X09.0B	125	125	140	140	9	10
MXP-125X140X11.4B	125	125	140	140	11.4	12.4
MXP-125X140X09.0B	125	125	140	140	9	10
MXP-125X145X14.5B	125	125	145	145	14.5	15.5
MXP-125X145X15.0B	125	125	145	145	15	16
MXP-125X150X12.0B	125	125	150	150	12	13
MXP-125X150X18.0B	125	125	150	150	18	19
MXP-130X145X09.0B	130	130	145	145	9	10
MXP-130X145X09.0B	130	130	145	145	9	10
MXP-130X150X12.0B	130	130	150	150	12	13
MXP-130X150X13.0B	130	130	150	150	13	14
MXP-130X150X15.0B	130	130	150	150	15	16
MXP-130X150X16.0B	130	130	150	150	16	17
MXP-130X160X17.0B	130	130	160	160	17	18
MXP-135X150X09.0B	135	135	150	150	9	10
MXP-135X150X09.0B	135	135	150	150	9	10
MXP-135X155X15.0B	135	135	155	155	15	16

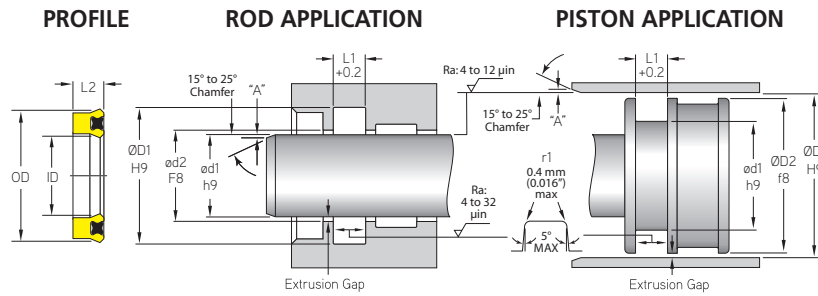

**METRIC X-PAC®
B-LIP**

MFP PART NUMBER	ROD OR PISTON APPLICATION					
	ØD1	ØD2	ØD1	ØD2	L2	L1
TOLERANCE	h9	F8	H9	f8		+0.2
MXP-136X150X09.0B	136	136	150	150	9	10
MXP-140X155X09.0B	140	140	155	155	9	10
MXP-140X155X09.0B	140	140	155	155	9	10
MXP-140X160X12.0B	140	140	160	160	12	13
MXP-140X160X13.0B	140	140	160	160	13	14
MXP-140X160X14.0B	140	140	160	160	14	15
MXP-140X160X14.5B	140	140	160	160	14.5	15.5
MXP-140X160X15.0B	140	140	160	160	15	16
MXP-140X165X18.2B	140	140	165	165	18.2	19.2
MXP-145X160X07.0B	145	145	160	160	7	8
MXP-145X160X09.0B	145	145	160	160	9	10
MXP-145X160X07.0B	145	145	160	160	7	8
MXP-145X160X09.0B	145	145	160	160	9	10
MXP-150X160X08.0B	150	150	160	160	8	9
MXP-150X165X09.0B	150	150	165	165	9	10
MXP-150X165X09.0B	150	150	165	165	9	10
MXP-150X170X15.0B	150	150	170	170	15	16
MXP-150X170X16.0B	150	150	170	170	16	17
MXP-150X180X18.0B	150	150	180	180	18	19
MXP-155X180X15.0B	155	155	180	180	15	16
MXP-155X180X16.0B	155	155	180	180	16	17
MXP-160X175X09.0B	160	160	175	175	9	10
MXP-160X180X09.5B	160	160	180	180	9.5	10.5
MXP-160X175X09.0B	160	160	175	175	9	10
MXP-160X180X15.0B	160	160	180	180	15	16
MXP-160X185X18.0B	160	160	185	185	18	19
MXP-160X190X16.0B	160	160	190	190	16	17
MXP-160X190X22.7B	160	160	190	190	22.7	23.7
MXP-165X180X09.5B	165	165	180	180	9.5	10.5
MXP-170X190X15.0B	170	170	190	190	15	16
MXP-170X195X16.0B	170	170	195	195	16	17
MXP-170X200X15.0B	170	170	200	200	15	16

METRIC SYMMETRICAL U-CUPS